



Redevelopment Authority

9955 N. Haggerty Road
Plymouth, MI 48170
734.354.3201

MITC-USA.ORG

Authority Board

Kurt Heise, Chairman
Mark Abbo, Vice Chairman
Gary Heitman
Joseph Vig
Glenn Cerny

BROWNFIELD PLAN, MITC PARCEL 13 AMENDMENT NO. 3

Plymouth Township and Northville Township, Michigan

Michigan International Technology Center Redevelopment Authority

c/o Kurt Heise, Chair
Michigan International Technology Center Redevelopment Authority
44405 Six Mile Road
Northville, MI 48168

Prepared with the assistance of:
Harless & Associates, LLC

April 26, 2023

TABLE OF CONTENTS

- PROJECT SUMMARY – AMENDMENT NO. 2 1**
- I. INTRODUCTION..... 1**
 - A. PLAN PURPOSE 1**
 - B. PROPERTY DESCRIPTION.....2**
 - C. BASIS OF ELIGIBILITY3**
 - D. PROJECT DESCRIPTION4**
- II. GENERAL DEFINITIONS AS USED IN THIS PLAN 6**
- III. BROWNFIELD PLAN 6**
 - A. DESCRIPTION OF COSTS TO BE PAID WITH TAX INCREMENT REVENUES AND SUMMARY OF ELIGIBLE ACTIVITIES6**
 - B. ESTIMATE OF CAPTURED TAXABLE VALUE AND TAX INCREMENT REVENUES.....7**
 - C. METHOD OF FINANCING PLAN COSTS AND DESCRIPTION OF ADVANCES BY THE MUNICIPALITY9**
 - D. MAXIMUM AMOUNT OF NOTE OR BONDED INDEBTEDNESS9**
 - E. DURATION OF BROWNFIELD PLAN9**
 - F. ESTIMATED IMPACT OF TAX INCREMENT FINANCING ON REVENUES OF TAXING JURISDICTIONS..... 10**
 - G. LEGAL DESCRIPTION, PROPERTY MAP, PROPERTY CHARACTERISTICS AND PERSONAL PROPERTY 10**
 - H. ESTIMATES OF RESIDENTS AND DISPLACEMENT OF FAMILIES 10**
 - I. PLAN FOR RELOCATION OF DISPLACED PERSONS 10**
 - J. PROVISIONS FOR RELOCATION COSTS..... 10**
 - K. STRATEGY FOR COMPLIANCE WITH MICHIGAN’S RELOCATION ASSISTANCE LAW 10**
 - L. DESCRIPTION OF THE PROPOSED USE OF LOCAL BROWNFIELD REVOLVING FUND (LBRF)..... 10**
 - M. OTHER MATERIAL THAT MITC OR GOVERNING BODIES CONSIDER PERTINENT 11**

FIGURES

FIGURE 1 – MITC REDEVELOPMENT AREA AND PARCEL MAP

FIGURE 2 – PROPERTY BOUNDARIES DIAGRAM

APPENDIX A

TABLE 1-1 SUMMARY OF ELIGIBLE ACTIVITIES AND COSTS – PARCEL 13

**TABLE 1-2 SUMMARY OF ELIGIBLE ACTIVITIES AND COSTS – PARCEL 11/12
(RIDGE 5 CORPORATE PARK)**

**TABLE 1-3 SUMMARY OF ELIGIBLE ACTIVITIES AND COSTS – MITC PUBLIC
INFRASTRUCTURE IMPROVEMENTS**

**TABLE 1-4 SUMMARY OF ELIGIBLE ACTIVITIES AND COSTS – WEST PORTION
PARCEL 9 (NORTHVILLE LUMBER CO.)**

APPENDIX B

TABLE 2-1 SUMMARY OF TIR CAPTURE FOR PARCEL 13

TABLE 2-2 SUMMARY OF TIR CAPTURE FOR PARCEL 11/12

TABLE 2-3 SUMMARY OF TIR CAPTURE FOR NORTHVILLE LUMBER CO.

APPENDIX C

**TABLE 3 TIR REIMBURSEMENT ALLOCATION (NORTHVILLE LUMBER CO.,
PARCEL 13, PARCEL 11/12, MITC INFRASTRUCTURE)**

APPENDIX D

LEGAL DESCRIPTIONS AND SURVEYS (NORTHVILLE LUMBER CO.)

LEGAL DESCRIPTIONS AND SURVEYS (PARCELS 6-15)

APPENDIX E

PROJECT CONCEPTUAL DRAWINGS – PARCEL 13

SITE PLAN – PARCEL 11/12

SITE PLAN AND PROJECT CONCEPTUAL DRAWINGS – NORTHVILLE LUMBER CO.

PROJECT SUMMARY – AMENDMENT NO. 3

Project Names:	<p>Northville Lumber Co. (portion of MITC Parcel 9)</p> <p>Other included projects: 5 & Ridge Flex Building (MITC Parcel 13); Ridge 5 Corporate Park (MITC Parcel 11/12); and MITC public infrastructure improvements.</p> <p>All are component developments in the Michigan International Technology Center Redevelopment Authority (MITC) Redevelopment Area.</p>
Developers:	<p>New Northville, LLC</p> <p>Other included project developers: Hillside Ridge Road Holdings East LLC; Hillside Ridge Road Holdings West LLC; and MITC Redevelopment Authority.</p>
Estimated Investments:	<p>Northville Lumber Co. - \$21,500,000</p> <p>Other included projects - \$110,500,000</p>
Project Locations:	<p>Approximately 27.39 acres (portion of MITC Parcel 9) at the northeastern corner of Ridge Road and Five Mile Road in Northville Township, Wayne County, Michigan.</p> <p>Other included project locations: approximately 7.96 acres (MITC Parcel 13) and 133.12 acres (MITC Parcel 11/12) at the southeast and southwest corners, respectively, of the intersection of Five Mile Road and Ridge Road in Plymouth Township, Wayne County, Michigan. The MITC infrastructure improvement projects are in roadway rights-of-way or public easements in the MITC Redevelopment Area, which comprises seven tax parcels, being nine MITC parcels (MITC Parcels 6, 7, 8, 9, 10, 11/12, 13, 14, and 15).</p>
Property Eligibilities:	<p>Northville Lumber Co. portion of Parcel 9 is eligible by meeting the definition of a facility as defined in Part 201 of the Michigan Natural Resources and Environmental Protection Act, as amended (Part 201), and being owned by the State Land Bank (SLB).</p> <p>Other parcel eligibilities: The other parcels of the Property are eligible by meeting the definition of a facility as defined in Part 201, being owned or previously owned by the SLB, or being adjacent or contiguous to a facility.</p>
Eligible Activities And Costs	<p>Tax increment revenues will be captured under this plan for deposit in the State Brownfield Revolving Fund (SBRF) and reimbursement of the following: MITC administrative expenses, costs of public infrastructure improvements that benefit the eligible Property, and developers' eligible brownfield redevelopment activities and costs described in this plan amendment. The total department specific (Michigan Department of Environment, Great Lakes and Energy (EGLE)) eligible and Michigan Strategic Fund (MSF) eligible costs included in this brownfield plan amendment for redevelopment of the Northville Lumber Co. portion of Parcel 9 are \$3,610,121.</p> <p>The total MSF eligible activities for the MITC public infrastructure improvements included in this Brownfield plan are increased by \$400,000 for construction of a public storm water management system serving multiple Parcel 9 redevelopment projects. The total department specific eligible and MSF eligible costs for MITC</p>

public infrastructure improvements included in this brownfield plan amendment are now \$29,865,534.

Eligible activities and costs for other parcels previously included in plan amendments are \$1,470,773 for Parcel 13 and \$29,425,534 for the MITC public infrastructure improvements, all to be reimbursed with incremental local and school operating taxes. The department specific eligible costs for redevelopment of Parcel 11/12 are \$1,356,494, to be reimbursed only with incremental local taxes.

Capture Periods: Capture period for all projects - 30 years.
Capture period for Parcel 9 (Northville Lumber Co. portion) – 22 years

Capture period for Parcel 13 – 20 years
Capture period for Parcel 11/12 – 8 years
Capture period for MITC infrastructure – 23 years.

Project Summaries: The Northville Lumber Co. redevelopment of the eastern portion of Parcel 9 is a lumber yard with an approximately 71,900 square-foot showroom plus exterior paved and gravel lumber storage areas and a maintenance building.

The redevelopment project for Parcel 13 is an approximately 66,952 square-foot, single-story, building designed for flexible commercial/industrial uses, such as research and development, office, laboratory, and warehouse activities.

The redevelopment project for Parcel 11/12 is an industrial park for up to eight individual office, warehouse, or light industrial facilities. The site will also contain greenspace and a hike-and-bike trail along the east bank of Johnson Creek.

The MITC public infrastructure will consist of upgrades to Five Mile Road, Ridge Road, potable water service, and sanitary sewer service serving the MITC Redevelopment Area.

I. INTRODUCTION

A. PLAN PURPOSE

The Michigan International Technology Center Redevelopment Authority (MITC), duly established by an interlocal agreement (the Interlocal Agreement) approved by the Governor on December 27, 2018, between the Charter Township of Northville Brownfield Redevelopment Authority (NTBRA) and the Charter Township of Plymouth Brownfield Redevelopment Authority (PTBRA) pursuant to the Urban Cooperation Act, Michigan Public Act 7 of 1967, as amended, and operating in accordance with the Brownfield Redevelopment Financing Act, Michigan Public Act 381 of 1996, MCLA 125.2651 et. seq., as amended (“Act 381”), is authorized to exercise its powers within the limits of the MITC Redevelopment Area.

The Plymouth Township Board of Trustees adopted the Brownfield Plan for Five Mile and Ridge Roads (Appendix F), hereinafter the Site #3 Brownfield Plan on September 11, 2018, for property owned by the SLB at 47500 Five Mile Road, located at the southeast corner of Five Mile Road and Ridge Road in the Charter Township of Plymouth, Michigan. Pursuant to the Interlocal Agreement, the parcel, also known as MITC Parcel 13 (Figure 1), is located within the jurisdiction of MITC in the MITC Redevelopment Area. . In February 2021, the Plymouth Township Board of Trustees amended the Site #3 Brownfield Plan to assign and incorporate all eligible activities to be conducted under that brownfield plan, and any future amendments, to the jurisdiction of MITC.

In December 2019, MITC and the two governing bodies approved an MITC Redevelopment Area Brownfield Plan (the Base Plan), which included all parcels of property and roadway rights-of-way in the MITC Redevelopment Area. The purpose of the Base Plan was to provide for capture of tax increment revenues (TIR) generated from redevelopment of the Redevelopment Area parcels to reimburse the following: 1) the costs of eligible brownfield redevelopment activities incurred by the parcel developers and 2) the costs of eligible critical public infrastructure improvements incurred by MITC to support redevelopment projects in the MITC Redevelopment Area.

The MITC approved Base Plan Amendment No. 1 in April 2020 to provide for reimbursement of eligible environmental costs incurred during redevelopment of MITC Parcel 11/12. In April 2021 the Base Plan was further amended (Base Plan Amendment No. 2) to remove MITC Parcels 11/12, 13, 14, and 15 and the approved eligible activities and costs for MITC Parcel 11/12 in preparation for their transfer to the Site #3 (MITC Parcel 13) Brownfield Plan; no tax capture had begun for these parcels. In April 2022 the Base Plan was further amended (Base Plan Amendment No. 3) to remove MITC Parcels 6, 7, 8, 9, and 10 in preparation for their transfer to the Site #3 (MITC Parcel 13) Brownfield Plan; no Act 381 eligible activities had occurred on these parcels, and no tax capture had occurred.

In April 2021 the Site #3 Brownfield Plan was renamed the Parcel 13 Brownfield Plan and was amended (Parcel 13 Brownfield Plan, Amendment No. 1) to add the adjacent or contiguous MITC Parcels 11/12, 14, and 15; incorporate the previously approved brownfield plan amendment for the adjacent Parcel 11/12; and update the reimbursable eligible activities and costs for redevelopment of the included parcels. The adjacent and contiguous parcels were expected to add value to the Parcel 13 redevelopment and the entire MITC Redevelopment Area by increasing marketability of the area for attracting new firms and employees and supporting improved public infrastructure.

MITC Parcels 6, 7, 8, 9, and 10 were added to the Parcel 13 Brownfield Plan in the Parcel 13 Brownfield Plan Amendment No. 2 in April 2022. The Parcel 13 Brownfield Plan now includes seven eligible tax parcels of land in the MITC Redevelopment Area comprising MITC Parcels 6, 7, 8, 9, 10, 11/12, 13, 14, and 15 (cumulatively “the Property”).

This Parcel 13 Brownfield Plan Amendment No. 3 (the “Plan Amendment”) was developed to add the MITC public infrastructure improvements and the eligible activities and costs for redevelopment of the western, approximately 27.39 acres of MITC Parcel 9 by New Northville, LLC.

MITC will implement this Plan Amendment to promote economic development of the MITC Redevelopment Area by encouraging and supporting redevelopment of the Property. The Plan Amendment allows MITC to capture TIR generated by redevelopment of the Property for reimbursement of the developers' costs of eligible activities required to prepare the individual parcels for safe redevelopment and reuse; capture TIR generated by redevelopment of the Property included in this Plan Amendment for reimbursement of MITC's costs of public infrastructure improvements supporting redevelopment of the Property; payments to the State Brownfield Redevelopment Fund (SBRF); and payment of MITC's annual administrative operating expenses. The capture and use of TIR generated by redevelopment of the Property are necessary to support needed environmental response actions on the Property, ensure the economic viability of each redevelopment project, and construct critical infrastructure in the MITC Redevelopment Area to ensure economic viability of MITC's redevelopment program.

B. PROPERTY DESCRIPTION

The Property consists of seven tax parcels occupying approximately 740 acres of land plus associated roadway rights-of-way (ROW) in the MITC Redevelopment Area. The Property lies in the Charter Township of Plymouth and the Charter Township of Northville, Wayne County, Michigan. The tax parcel identification numbers and current ownerships of the parcels included in this Plan Amendment are shown in the following table:

MITC PARCEL NUMBER	TAX PARCEL ID NO.	OWNERSHIP
6, 7, & 8	77-066-99-0002-702	State Land Bank
9 (Northville Lumber Co. portion)	77-066-99-0002-701	State Land Bank
9 (Remaining portion)	77-066-99-0002-701	State Land Bank
10	78-001-99-0001-703	City of Detroit
11	78-001-01-0000-000 78-001-01-0001-000 78-001-01-0002-000 78-001-01-0003-000 78-001-01-0004-000 78-001-01-0005-000 78-001-01-0006-000 78-001-01-0007-000 78-001-01-0008-000	Northville Downs, LLC
12	78-001-01-0009-000	Hillside Ridge Road Holdings West, LLC
13	78-006-99-0001-710	Hillside Ridge Road Holdings East, LLC (formerly State Land Bank)
14	78-006-99-0001-002	BCP Plymouth LLC
15	78-006-99-0001-711	State Land Bank
All	Adjoining road rights-of-way	Wayne County

The Property (Figure 2) is located on the north and south sides of Five Mile Road between Beck Road and Napier Road. Napier Road is the western boundary of the Property, and developed land along Beck Road forms the eastern boundary. Residential neighborhoods, a commercial landfill, and undeveloped land lie north of the Property, and residential and light industrial developments and undeveloped land lie

south of the Property. The C&O Railroad right-of-way, Ridge Road, Five Mile Road, and Johnson Creek bisect the Property.

The Property is a portion of a larger area, approximately 800 acres of land, that was formerly occupied by the Detroit House of Correction and the Western Wayne County Correctional Facility (the DeHoCo site) and associated agricultural land. The Property was used for agricultural purposes from at least the early 1900's until it was acquired by the City of Detroit as part of the approximately 800-acre acquisition. The larger site was first developed by the City of Detroit in 1920 as a prison camp. The city completed construction of a permanent, maximum-security prison, the Detroit House of Correction (DeHoCo), on what is now MITC Parcel 15. The land outside the secure prison was developed for agriculture and used as a prison farm until the mid-20th century. The city sold the prison facility to the State of Michigan Department of Corrections in two transactions, one in 1979 and the other in 1985. The prison facility was renamed the Western Wayne County Correctional Facility and was operated as a men's prison until its closure in 2004. A portion of the prison property (MITC Parcels 13 and 15) was transferred to the State Land Bank (SLB) in 2014. MITC Parcel 10 was retained by the City of Detroit, and the other parcels were subsequently acquired by Plymouth Township, Northville Township, and other private parties. Ownership of MITC Parcels 3 through 9 were transferred from Northville Township to the SLB in 2022.

The proposed redevelopment for this Plan Amendment is a lumber yard to be developed by New Northville, LLC on the western, approximately 27.4 acres of the approximately 81.57-acre, MITC Parcel 9. This portion of Parcel 9, known as the Northville Lumber Co. parcel, is currently vacant and vegetated.

Proposed redevelopment projects on MITC Parcels 11/12 and 13 were previously included in the Parcel 13 Brownfield Plan (Amendment 1). Parcel 11/12 is approximately 133.12 acres of land where site infrastructure has been constructed to support the planned Ridge 5 Corporate Park with building sites for up to eight individual industrial/commercial developments. MITC Parcel 13 is approximately 7.96 acres of land that is currently vegetated and undeveloped.

MITC Parcel 14 comprises approximately 105 acres of land that is currently undergoing redevelopment with construction of a large warehouse/light industrial building, the first of multiple planned buildings. Redevelopment plans are currently being developed for all or parts of MITC Parcels 7, 8, 10, and 15. MITC Parcels 7, 8, and 10 are currently vegetated, vacant land. MITC Parcel 15 is the site of the former DeHoCo prison facilities; all above-ground structures have been demolished, and the Property is now undeveloped and generally vegetated, except for remnant pavements and building foundations.

C. BASIS OF ELIGIBILITY

MITC Parcel 13 was determined to be eligible for inclusion in the Site #3 Brownfield Plan in accordance with MCL 125.2652(p) because it was owned by the SLB at the time of inclusion and meets the definition of a "facility" pursuant to Part 201 of Michigan's Natural Resources and Environmental Protection Act (1994 P.A. 451, as amended), hereinafter "Part 201". Eligibilities of all parcels included in the Property definition and this Plan Amendment are described in the following table:

MITC PARCEL NUMBER	TAX PARCEL ID NO.	BASIS FOR ELIGIBILITY
6, 7, & 8	77-066-99-0002-702	Owned by State Land Bank; Part 201 Facility
9 (New Northville portion)	77-066-99-0002-701	Owned by State Land Bank; Part 201 Facility
9 (Remaining portion)	77-066-99-0002-701	Owned by State Land Bank; Part 201 Facility

MITC PARCEL NUMBER	TAX PARCEL ID NO.	BASIS FOR ELIGIBILITY
10	78-001-99-0001-703	Contiguous with Part 201 Facility
11	78-001-01-0000-000 78-001-01-0001-000 78-001-01-0002-000 78-001-01-0003-000 78-001-01-0004-000 78-001-01-0005-000 78-001-01-0006-000 78-001-01-0007-000 78-001-01-0008-000	Part 201 Facility
12	78-001-01-0009-000	Adjacent to Part 201 Facility
13	78-006-99-0001-710	Included in Brownfield Plan while owned by State Land Bank; Part 201 Facility
14	78-006-99-0001-002	Adjacent to Part 201 Facility
15	78-006-99-0001-711	Owned by State Land Bank; Part 201 Facility
All	Adjoining road rights-of-way	Adjacent to eligible property

D. PROJECT DESCRIPTION

THE REDEVELOPMENT

The two townships, through their respective Brownfield Redevelopment Authorities and supported by Wayne County and the SLB, created MITC as a joint venture to promote and support the redevelopment of approximately 800 acres of land (including the Property), occupying 10 individual tax parcels (15 MITC Parcels; Figure 1), for technology research and light industrial uses. The Property includes ten MITC parcels (Figure 2) that will be redeveloped, transforming the currently vacant parcels into tax-producing, job-creating industrial/commercial developments. Redevelopment of the Property will be supported by local public infrastructure improvements, which both Plymouth Township and Northville Township have determined are critical for supporting the redevelopments described in this plan and catalyzing additional redevelopment in the area.

New Northville, LLC will redevelop the western approximately 27.4 acres of MITC Parcel 9 as the Northville Lumber Co. lumber yard. A site plan and conceptual drawings of the project are attached in Appendix e. The development will include an approximately 75,000 square-foot main building along with an approximately 6,250 square foot maintenance building and associated large outdoor lumber storage areas. The main building will accommodate office, showroom, and indoor storage uses. The site will be accessed by two driveways onto Five Mile Road and one driveway onto Napier Road. Site development also includes the creation of a large, off-site, stormwater detention pond, berming of existing contaminated soils, and public infrastructure improvements, including sidewalks, curbs, asphalt paving, and landscaping in the Five Mile Road and Napier Road public ROWs. These infrastructure improvements are separate from, and not duplicative of, the public infrastructure improvements to be constructed by MITC. It is anticipated that approximately 350 temporary construction-related jobs will be created and approximately 105 permanent full-time equivalent jobs with an average hourly wage of \$22.75 will be created and/or brought to the new facility. The projected cost of the project is approximately \$21,500,000. Construction is currently expected to begin in the summer of 2023 and completed in 2024.

The proposed development on MITC Parcel 13 is a single, flexible-use, commercial/industrial building having a footprint of approximately 65,952 square feet. The single-story building can accommodate office, research and development, laboratory, and/or warehouse uses. A site plan and conceptual renderings of the project are attached in Appendix E. Site development also includes the creation of a large stormwater detention pond and public infrastructure improvements, including sidewalks, curbs, asphalt paving, and landscaping in the Five Mile Road and Ridge Road public ROWs. These infrastructure improvements are separate from, and are not duplicative of, the infrastructure improvements to be constructed by MITC. It is anticipated that approximately 350 temporary construction-related jobs will be created and approximately 160 permanent full-time equivalent jobs with an average hourly wage of \$31.25 will be created. The projected cost of the project is approximately \$10,150,000. Construction is currently expected to begin in late 2022, and eligible activities will be completed within 18-24 months.

The Ridge 5 Corporate Park is proposed to be an industrial business park with eight lots for light industrial and commercial occupancy. A site plan of the project is attached in Appendix D. The industrial park will be accessed via a single roadway connecting to Ridge Road. Greenspace will be maintained on the Property's southeast corner, and a pedestrian path will be constructed on the west side of the property along Johnson Creek. Specialized stormwater management ponds will be installed on the southern and northern sides of the Property to protect the biota of Johnson Creek Drain. The on-site infrastructure for redevelopment of MITC Parcel 11/12 into the Ridge 5 Corporate Park has been constructed. It is anticipated that approximately 75-100 temporary construction-related jobs will be created, and over 1,000 permanent full-time equivalent jobs will be created at full occupancy. The estimated cost of the project when all land has been developed is approximately \$100,000,000. Site preparation began in 2019 and was completed in 2021. Site infrastructure has been constructed, and the lots are now being marketed for development.

Critical upgrades of the sanitary sewer and potable water systems and roadway infrastructure in the Redevelopment Area are needed. MITC estimates that approximately \$28 million in improvements to this infrastructure will be required to successfully execute the redevelopment plans. MITC will use TIR generated from redevelopment projects on property in the MITC Redevelopment Area to fund expansion of water and sanitary sewer service to parcels lying west of Ridge Road and improve Five Mile Road and Ridge Road in the MITC Redevelopment area. MITC plans to obtain external capital to fund the infrastructure improvements and then reimburse the capital sources using TIR captured from redevelopment projects included in the Plan, as may be amended in the future.

BROWNFIELD CONDITIONS

Redevelopment of the Property is hindered by the presence of known environmental contamination on MITC Parcels, 6, 8, 9, 11/12, 13, and 15. Contamination is also possible on the other parcels in this Plan Amendment, but environmental assessment data is not available. Arsenic is present in soil on Parcel 13 at levels greater than generic residential use criteria described in Part 201. Groundwater is contaminated with tetrachloroethene at levels that pose a potential risk to occupants of future buildings via the drinking water, groundwater-surface water protection, and vapor intrusion pathways. Waste materials in an unregulated disposal area on Parcel 15 are suspected to encroach on the southeastern portion of Parcel 13. Some foundations and footings of previous agricultural buildings and silos remain on the Property, as does fill unsuitable for construction.

Known brownfield conditions on other parcels included in this Plan Amendment are summarized below:

- MITC Parcel 6 - Soil is contaminated with arsenic at concentrations greater than the Part 201 default residential direct contact and drinking water protection criteria and with cobalt at a concentration greater than groundwater protection criteria. Groundwater is contaminated with iron and manganese at levels above drinking water protection criteria and ammonia at a level greater than the surface water protection criterion.
- MITC Parcel 8 - Arsenic is present in soil at concentrations greater than the Part 201 default residential direct contact and drinking water protection criteria, and selenium is present at a concentration greater than the groundwater protection criterion. Groundwater is contaminated with iron and manganese at levels above drinking water protection criteria and cyanide at a level greater than the surface water protection criterion.

- MITC Parcel 9 (Northville Lumber Co. portion) – Soil is contaminated with arsenic at concentrations above its default residential direct contact criterion and aluminum, arsenic, chromium, cobalt, iron, magnesium, manganese, and selenium at concentrations above their respective groundwater protection criteria. Iron, aluminum, manganese and chloride are present in groundwater at levels greater than drinking water protection criteria.
- MITC Parcel 9 (Remainder portion) – Soil is contaminated with arsenic at concentrations above its default residential direct contact criterion and arsenic, cobalt, manganese, and selenium at concentrations above their respective groundwater protection criteria. Manganese is present in groundwater at levels greater than drinking water protection criteria.
- MITC Parcel 11 – Arsenic, cadmium, copper, mercury, selenium, and zinc are present in soil at levels above residential cleanup criteria on this parcel. Groundwater is contaminated with cadmium at concentrations greater than its residential use criterion. Residual structures from previous site use activities remain on the parcel.
- MITC Parcel 15 – Soil is contaminated with the following constituents at levels greater than groundwater protection criteria: benzene, n-propylbenzene, toluene, xylenes, trimethylbenzenes, trichloroethene, tetrachloroethene, naphthalene, phenanthrene, PCBs, arsenic, cadmium, chromium, copper, lead, mercury, selenium, silver, and zinc. Soil is contaminated with the following compounds at concentrations greater than residential and non-residential human direct contact cleanup criteria: PCBs, arsenic, and lead. Soil is contaminated with the following compounds at concentrations at levels that may pose a risk to occupants of future buildings via the vapor intrusion pathway: benzene, ethylbenzene, xylenes, trimethylbenzenes, trichloroethene, tetrachloroethene, *cis*-dichloroethene, 1,4-dichlorobenzene, methane, and mercury.

Arsenic and barium are present in groundwater at levels above drinking water and surface water protection criteria. Levels of benzene and vinyl chloride are above vapor intrusion screening levels in soil gas.

Multiple, unregulated waste disposal areas are also present on this parcel. Residual building foundations, underground utilities, and pavements remain on the site as remnants of demolished former prison buildings.

The developers of these parcels will incur additional redevelopment costs to protect human health and the environment from the hazards posed by the identified contamination in compliance with their Part 201 due care obligations. They will also incur non-environmental redevelopment costs for eligible demolition, site preparation, and additional public infrastructure activities.

II. GENERAL DEFINITIONS AS USED IN THIS PLAN

All words or phrases not defined herein shall have the same meaning as such words and phrases included in Act 381.

III. BROWNFIELD PLAN

A. DESCRIPTION OF COSTS TO BE PAID WITH TAX INCREMENT REVENUES AND SUMMARY OF ELIGIBLE ACTIVITIES

The costs of eligible activities included in, and authorized by, this Plan Amendment will be reimbursed with incremental local tax revenues and incremental state school operating tax revenues generated from the Property and captured by MITC. TIR will be determined individually for each parcel. Reimbursement will be subject to any limitations and conditions imposed by the following: parcel eligibilities determined pursuant to Act 381; this Plan Amendment; Act 381 work plan approvals by the EGLE and the MSF for school operating tax capture; and the terms of the Reimbursement Agreement between MITC and the parties eligible to receive tax increment reimbursement. If available, this Plan Amendment will also capture all new personal property taxes generated by redevelopment of the Property.

The estimated total costs of Department Specific and MSF eligible activities, Brownfield Plan Amendment preparation, and Act 381 Work Plan preparation and implementation activities associated with redevelopment of the Property that are eligible for reimbursement from TIR under this Plan Amendment are \$36,265,422. The eligible Department Specific and MSF Eligible activities for the three redevelopment projects and the MITC infrastructure project included in this Plan Amendment are summarized in project-specific Tables of Eligible Activities (Table 1-1 through Table 1-4) attached in Appendix A. The total reimbursable costs for the brownfield redevelopment projects included in this Plan Amendment are as follows:

- MITC Parcel 9 (New Northville, LLC portion) - \$4,012,621
- MITC Parcel 13 - \$1,470,773
- MITC Parcel 11/12 - \$1,356,494
- MITC public infrastructure improvements - \$29,865,534.

The costs of individual Department Specific (environmental) and MSF Eligible (non-environmental) activities eligible for reimbursement under this Plan Amendment are estimated and may increase or decrease, depending on the nature and extent of unknown conditions and situations encountered during redevelopment. The Reimbursement Agreements and this Plan Amendment will dictate the total cost of eligible activities subject to reimbursement for the developer of each parcel and for MITC for public infrastructure. As long as the applicable total cost limits described in this Plan Amendment for the eligible activities on each parcel included in this Plan Amendment (Tables 1-1, 1-2, and 1-4) and for the MITC public infrastructure (Table 1-3) are not exceeded, line-item eligible activities, tasks, and costs within the eligible Department Specific activities and MSF Eligible activities categories relevant to the individual parcel and the MITC public infrastructure may be adjusted after the date of this Plan Amendment without additional Plan amendment, to the extent the adjustments do not violate Act 381. No costs of eligible activities will be qualified for reimbursement except to the extent permitted in accordance with the terms and conditions of the Reimbursement Agreements for each entity incurring brownfield redevelopment costs under this plan and with Act 381.

The contingency funds for reimbursement of the Department Specific and MSF Eligible Activities described in Table 1-1 through Table 1-4 may be applied when the respective cumulative eligible Department Specific or MSF Eligible expenses for those activities eligible for contingency application are exceeded. Eligible activities conducted prior to Brownfield Plan approval will be reimbursed to the extent allowed by Act 381 and as provided in the approved Plan Amendment and the Reimbursement Agreement.

Fifty percent (50%) of the available incremental State Education Tax will be captured for deposit into the SBRF pursuant to Act 381. MITC will capture annual local TIR up to the maximum allowed by Act 381 to fund its administrative costs of operations. MITC will also capture incremental local and state school tax revenues annually under this Plan Amendment, to the extent possible during the term of this Plan Amendment, to reimburse the costs of MITC's public infrastructure improvements associated with the Property. The amounts of TIR captured for administrative costs and infrastructure reimbursement are defined in the tax increment reimbursement tables attached to this Plan Amendment and in the Reimbursement Agreement for each parcel/project.

B. ESTIMATE OF CAPTURED TAXABLE VALUE AND TAX INCREMENT REVENUES

The initial taxable values and projected taxable values, if under development, for MITC parcels included in this Plan Amendment are presented in the following table; however, the actual taxable value in each year of this Plan Amendment will be determined by the Plymouth Township and Northville Township Assessors.

MITC PARCEL NUMBER	TAX PARCEL ID NO.	INITIAL TAXABLE VALUE	PROJECTED TAXABLE VALUE OF ACTIVE DEVELOPMENTS
6, 7, & 8	77-066-99-0002-702	\$0	NA
9 (Northville Lumber Co. portion)	77-066-99-0002-701	\$0	\$3,500,000
9 (Remainder portion)	77-066-99-0002-701	\$0	NA
10	78-001-01-0000-000 78-001-01-0001-000 78-001-01-0002-000 78-001-01-0003-000 78-001-01-0004-000 78-001-01-0005-000 78-001-01-0006-000 78-001-01-0007-000 78-001-01-0008-000	\$0	NA
11	78-001-01-0009-000		NA
12	78-001-99-0001-704	\$0	\$30,000,000
13	78-006-99-0001-710	\$0	\$2,846,680
14	78-006-99-0001-002	\$1,093,233	NA
15	78-006-99-0001-711	\$0	NA

Estimated taxable values, TIR to be captured and impacts on taxing jurisdictions are presented in Table 2-1 through Table 2-3, attached in Appendix B. Eligible activities reimbursement cash flows are presented in Table 3, attached in Appendix C. The annual increase in taxable value of the Property is assumed to be 2% for purposes of this Plan Amendment. The annual incremental taxable value and captured tax increment revenue will be determined by the actual assessed taxable value of each parcel of the Property and the millages approved by the relevant taxing jurisdictions.

Since the Site #3 Brownfield Plan for Parcel 13 was approved in 2018, the projected TIR capture starting date (2024) for the Northville Lumber Co. redevelopment is year 6 for the Parcel 13 Brownfield Plan, which is carried into this plan as year 6 of the Plan Amendment. Tax increment revenue was first captured from Parcel 13 in 2019, which began the 30-year maximum capture period for this Plan.

MITC will capture 100% of the available incremental local and school operating tax revenues generated from the Property to reimburse the costs of eligible activities under this Plan Amendment in accordance with the respective Reimbursement Agreements and approved Act 381 Work Plans. Incremental tax revenue associated with all new personal property will also be captured as part of this plan. Reimbursement using incremental school operating tax revenues is limited to those eligible activities and costs approved by EGLE and/or MSF or that are otherwise eligible under Act 381.

It is the intent of this Plan Amendment to provide for the proportional capture of all eligible incremental taxes in whatever amounts and years they become available until the eligible cost reimbursements described in this Plan Amendment are complete or for the maximum duration provided in Act 381, whichever is shorter. Eligible costs for a Baseline Environmental Assessment (BEA), Due Care assessment, Due Care planning, and for preparation of Brownfield Plan(s) and Act 381 Work Plan(s) for each parcel included in this Plan Amendment will be reimbursed with incremental local and state school tax revenues to the extent allowed by Act 381; these costs are not subject to approval of an Act 381 Work Plan.

Eligible environmental and non-environmental activities for Parcel 13 (Table 1-1), the MITC public infrastructure improvements (Table 1-2), and Parcel 9 (Northville Lumber Co. portion; Table 1-4) will be reimbursed with local and state school operating TIR to the extent allowed by Act 381 and approved Act 381 Work Plans. The eligible response activities described in Table 1-3 for Parcel 11/12 will be reimbursed only with local TIR.

Except for those activities identified in this Plan as eligible for reimbursement only with incremental local taxes, if EGLE or MSF elects not to participate in this Project or declines to approve certain eligible activities for reimbursement with incremental state school taxes, the other taxing entities will contribute only that proportionate share of capture (the local tax increments) and reimbursement that would be contributed if EGLE or MSF had approved capture of state school operating taxes.

C. METHOD OF FINANCING PLAN COSTS AND DESCRIPTION OF ADVANCES BY THE MUNICIPALITY

The developers of each parcel in this Plan Amendment will be responsible for financing the costs of eligible activities for the brownfield redevelopment project on that parcel. Neither MITC nor the local governing bodies will advance any funds to finance the costs of eligible activities that are incurred by the developers of the Property.

Public infrastructure improvements undertaken in the Five Mile Road corridor to support the MITC redevelopment program will be funded by third parties. Act 381 TIR arising from brownfield redevelopment of the Property is anticipated to be the source for repayment of the costs of public infrastructure improvements. Notwithstanding the foregoing, if the water and sewer improvements cannot be funded by third parties, the local Township Boards may elect to 1) fund or incur financial obligations to fund the water improvements and 2) request the Western Townships Utility Authority (WTUA) to fund the sewer improvements. Tax increment revenues will be used to reimburse the Townships and/or WTUA for such funding or financing of the public infrastructure improvements as provided in the respective Reimbursement Agreements. The MITC and two townships may also act as pass-through entities for any grants-in-aid provided to fund project activities.

The inclusion of eligible activities and estimates of costs to be reimbursed pursuant to this Plan Amendment is intended to authorize the MITC to fund such reimbursements. The amount and source of any TIR that will be used for purposes authorized by this Plan, and the terms and conditions for such use and any reimbursement of the expenses permitted by the Plan, will be provided solely under the respective Reimbursement Agreements. Reimbursements under each Reimbursement Agreement shall not exceed the respective cumulative eligible costs or any reimbursement period limits described in this Plan Amendment, unless further amended.

D. MAXIMUM AMOUNT OF NOTE OR BONDED INDEBTEDNESS

Not applicable.

E. DURATION OF BROWNFIELD PLAN

The duration of this Brownfield Plan Amendment shall not exceed the shorter of the following time periods without further brownfield plan amendment: 1) reimbursement of all eligible costs, cumulatively not to exceed reimbursement of the costs of developers' eligible activities plus reimbursement of MITC's costs for public infrastructure improvements or 2) until 30 years after first capture of TIR under the Site #3 (Parcel 13) Brownfield Plan. The date for beginning tax capture for Parcel 13 and Parcel 11/12 was tax year 2021. The estimated start date for beginning tax capture for the Northville Lumber Co. parcel is 2024.

F. ESTIMATED IMPACT OF TAX INCREMENT FINANCING ON REVENUES OF TAXING JURISDICTIONS

MITC will capture available incremental local and school operating tax revenues generated by the redeveloped Property until all incurred eligible environmental and non-environmental brownfield redevelopment costs and MITC administrative expenses are reimbursed to the extent described in this Plan Amendment. The TIR available for capture by MITC will be captured in equal proportions from local and state school operating tax revenue sources based on the approved millage rates for each tax year in which TIR are captured; 100% of available local and state school operating TIR will be captured. The impact of the incremental tax capture on local taxing jurisdictions is presented in the Tax Increment Capture Estimate Tables, Table 2-1, Table 2-2, and Table 2-3 attached in Appendix B.

G. LEGAL DESCRIPTION, PROPERTY MAP, PROPERTY CHARACTERISTICS AND PERSONAL PROPERTY

The Property consists of approximately 740 acres of land in Plymouth Township. It comprises Parcel 6, 7, 8, 9, 10, 11/12, 13, 14, and 15 in the MITC Redevelopment Area. Property surveys and legal descriptions of Parcel 9 (Northville Lumber Co. portion, Parcel 9 (remainder), Parcel 11/12 and Parcel 13, the parcels currently proposed for reimbursement of eligible brownfield redevelopment costs under this Plan Amendment, are attached in Appendix D.

H. ESTIMATES OF RESIDENTS AND DISPLACEMENT OF FAMILIES

No occupied residences are involved in the redevelopment, no persons reside on the Property, and no families or individuals will be displaced as a result of this development. Therefore, a demographic survey and information regarding housing in the community are not applicable and are not needed for this Plan Amendment.

I. PLAN FOR RELOCATION OF DISPLACED PERSONS

No persons will be displaced as a result of this development; therefore, a plan for relocation of displaced persons is not applicable and is not needed for this Plan Amendment.

J. PROVISIONS FOR RELOCATION COSTS

No persons will be displaced as result of this development and no relocation costs will be incurred; therefore, provision for relocation costs is not applicable and is not needed for this Plan Amendment.

K. STRATEGY FOR COMPLIANCE WITH MICHIGAN'S RELOCATION ASSISTANCE LAW

No persons will be displaced as result of this development; therefore, no relocation assistance strategy is needed for this Plan Amendment.

L. DESCRIPTION OF THE PROPOSED USE OF LOCAL BROWNFIELD REVOLVING FUND (LBRF)

At the time of this Plan Amendment, MITC has not established an LBRF and does not currently plan to establish and fund an LBRF or use LBRF funds to support redevelopment activities described in this Plan Amendment. However, MITC reserves the right to establish and fund an LBRF with TIR generated from the Property included in this Plan Amendment in the future in accordance with Act 381 and use LBRF funds to support redevelopment of the Property and/or other brownfield sites within the MITC Redevelopment Area.

M. OTHER MATERIAL THAT MITC OR GOVERNING BODIES CONSIDER PERTINENT

The incremental tax revenues collected under this Plan Amendment will be adjusted as necessary to account for all precedent tax sharing and/or abatement programs. At the time of this Plan Amendment, Parcel 13 is subject to the SLB 5/50 Tax through tax year 2023. The Northville Lumber Co. parcel will be subject to the SLB 5/50 Tax for five years beginning with the first year of taxation after sale to New Northville, LLC, which is anticipated to be tax years 2024 through 2028.

MITC anticipates that some developments on the Property will seek and be granted an Industrial Development District designation and Michigan Industrial Facilities Tax (IFT) Exemption under P.A. 198 of 1974, as amended. An IFT Exemption awarded to a redevelopment project will reduce the TIR captured from the project parcel by approximately 50% during the exemption period. At the time this Plan Amendment was prepared, the Parcel 14 redevelopment had been granted a 7-year, Industrial Development District designation.

The MITC public infrastructure improvements component of this Plan Amendment has been updated with the inclusion of the Western Storm Water Management System to serve multiple redevelopment projects on a subdivided MITC Parcel 9. The estimated cost for this MSF eligible activity is \$400,000.

This Plan Amendment has been duly approved by resolutions of the Board of Trustees of the Charter Township of Northville and the Board of Trustees of the Charter Township of Plymouth and includes any limitations and/or conditions in those approvals.

FIGURES

FIGURE 1 – MITC REDEVELOPMENT AREA AND PARCEL MAP

FIGURE 2 – PROPERTY BOUNDARIES DIAGRAM

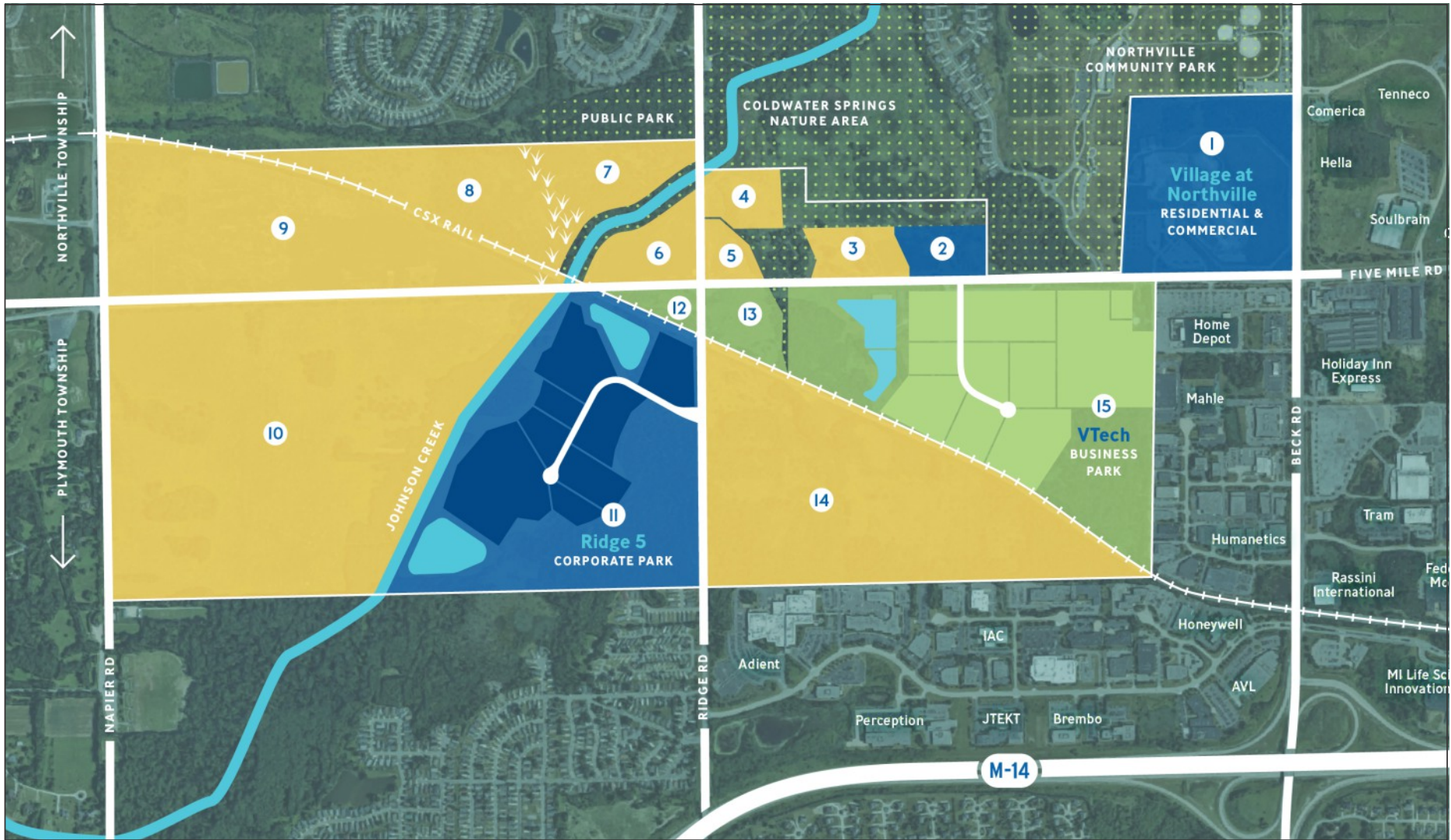

Date: February 23, 2022
Project #: HA001.20
Scale: Not To Scale

FIGURE NO. 1
MITC REDEVELOPMENT AREA
MITC PARCEL 13 BROWNFIELD PLAN
AMENDMENT NO. 3

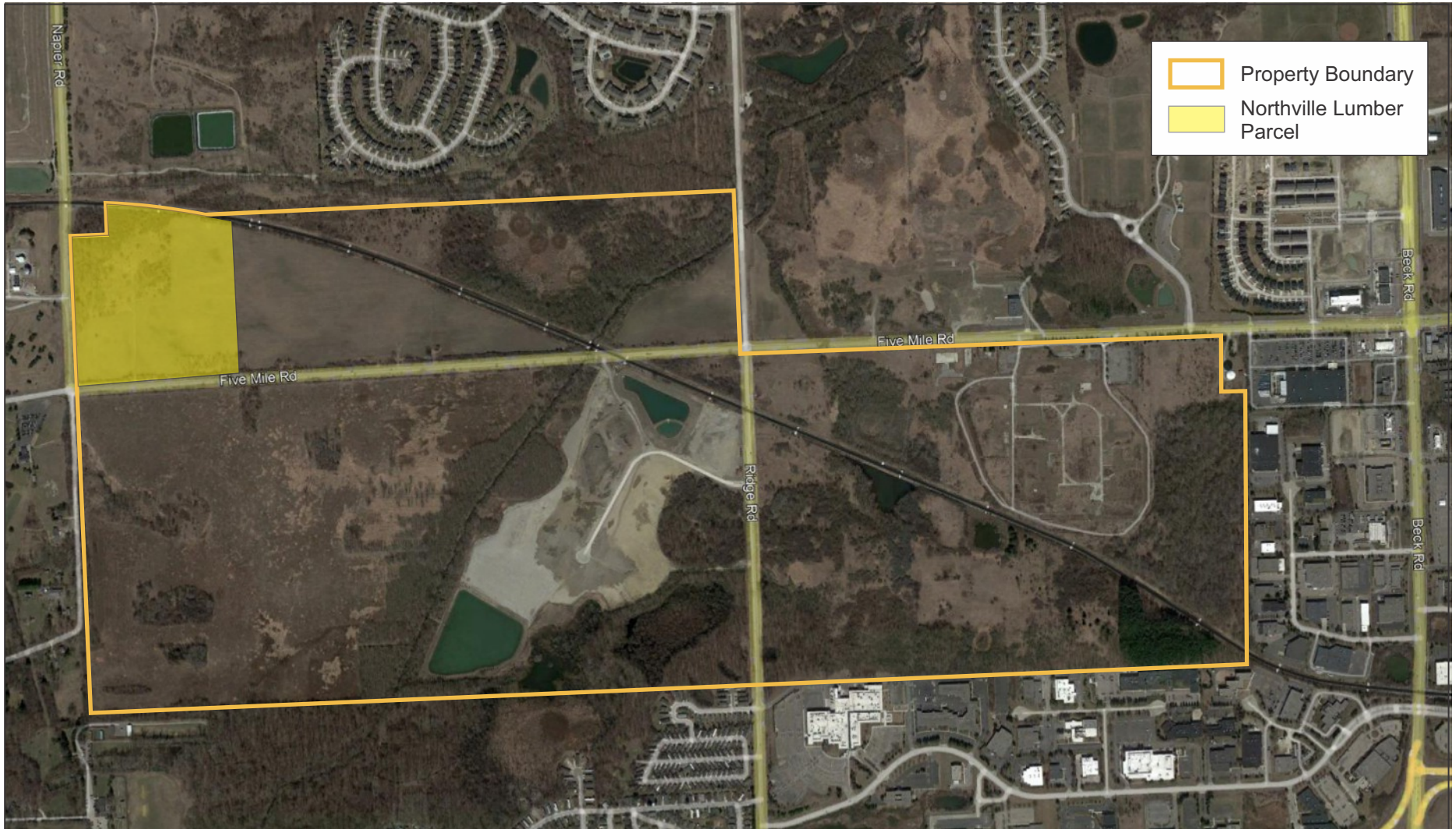

Date: February 23, 2022
Project #: HA001.20
Scale: Not To Scale

FIGURE NO. 2
PROPERTY BOUNDARY
MITC PARCEL 13 BROWNFIELD PLAN
AMENDMENT NO. 3

APPENDIX A

TABLE 1-1 SUMMARY OF ELIGIBLE ACTIVITIES AND COSTS – PARCEL 13

**TABLE 1-2 SUMMARY OF ELIGIBLE ACTIVITIES AND COSTS – PARCEL 11/12
(RIDGE 5 CORPORATE PARK)**

**TABLE 1-3 SUMMARY OF ELIGIBLE ACTIVITIES AND COSTS – MITC PUBLIC
INFRASTRUCTURE IMPROVEMENTS**

**TABLE 1-4 SUMMARY OF ELIGIBLE ACTIVITIES AND COSTS – PARCEL 9
(NORTHVILLE LUMBER CO. PORTION)**



**TABLE 1-1
BROWNFIELD ELIGIBLE ACTIVITIES COST SUMMARY
Parcel 13**

3/1/2022

ELIGIBLE ACTIVITIES	TOTAL ELIGIBLE COST
ELIGIBLE DEPARTMENT SPECIFIC (EGLE) ACTIVITIES⁽¹⁾	
Due Care Activities Due Care Planning and Coordination Due Care Investigations Due Care Plans and Documentation Management and Disposal of Contaminated Soil Management and Disposal of Contaminated Dewatering Effluent Dust, Runoff, and Track-out Control Field Monitoring and Project Management Due Care Design, Engineering, Management and Coordination	\$289,618
Brownfield Plan, Act 381 Work Plan, and Implementation⁽²⁾	\$30,000
Subtotal Department Specific Activities	\$319,618
Contingency (15%)	\$34,443
Total Department Specific Activities	\$354,061
ELIGIBLE NON-ENVIRONMENTAL (MSF) ACTIVITIES⁽¹⁾	
Demolition Activities Remnant Foundations and Utilities Removal	\$50,000
Public Infrastructure Improvements - Roadway Improvemnts ROW and Site Access Improvements Architectural and Engineering Desgin Site Construction Management Construction General Conditions	\$47,200
Site Preparartion Activities Clearing and Grubbing Temporary Facilities Surveying and Staking Excavation and Transport of Unsuitable Soil Imported Fill Dewatering Utility Relocation Onsite Specialized Foundations Field Monitoring and Project Management Architectural and Engineering Desgin Site Construction Management Construction General Conditions	\$852,112
Act 381 Work Plans and Implementation⁽²⁾	\$25,000
Subtotal Department Specific Activities	\$974,312
Contingency (10%)	\$142,397
Total Non-Environmental Activities	\$1,116,709
TOTAL ELIGIBLE ACTIVITIES⁽³⁾	\$1,470,770

Notes:

⁽¹⁾ Cost estimates are based on engineering, contractor, or developer estimates or consultant experience.

⁽²⁾ These costs are not included in the contingency calculation.



TABLE 1-2

BROWNFIELD ELIGIBLE ACTIVITIES COST SUMMARY
Parcels 11/12 - Ridge 5 Corporate Park

3/1/2022

ELIGIBLE ACTIVITIES	TOTAL ELIGIBLE COSTS
ELIGIBLE DEPARTMENT SPECIFIC (EGLE) ACTIVITIES⁽¹⁾	
BEA Activities⁽²⁾ Phase I ESA Phase II ESA BEA Report	\$33,500
Due Care Activities Due Care Planning and Coordination Due Care Assessment Remediation of Waste Disposal Area Due Care Site Monitoring During Construction	\$56,500
Other Response Activities Construction of Deep Stormwater Containment Systems Transportation and Disposal of Excess Soil Stormwater Pumping Systems	\$1,072,190
Act 381 Work Plan⁽²⁾	\$10,000
<i>Subtotal Department Specific Activities</i>	<i>\$1,172,190</i>
Contingency (15%)	\$169,304
<i>Total Department Specific Activities</i>	<i>\$1,341,494</i>
BROWNFIELD PLAN	
Brownfield Plan	\$15,000
TOTAL ELIGIBLE ACTIVITIES⁽³⁾	\$1,356,494

Notes:

⁽¹⁾ Cost estimates are based on engineering, contractor, or developer estimates or consultant experience.

⁽²⁾ These costs are not included in the contingency calculation.



**TABLE 1-3
BROWNFIELD ELIGIBLE ACTIVITIES COST SUMMARY
MITC Infrastructure**

4/22/2022

ELIGIBLE ACTIVITIES	TOTAL ELIGIBLE COST
ELIGIBLE DEPARTMENT SPECIFIC (EGLE) ACTIVITIES⁽¹⁾	
Due Care Activities	
Due Care Planning and Coordination	
Due Care Investigations	
Due Care Plans and Documentation	
Management and Disposal of Contaminated Soil	\$800,000
Management and Disposal of Contaminated Dewatering Effluent	
Dust, Runoff, and Track-out Control	
Prevent Exacerbation of Contaminated Groundwater - Utilities	
Prevent Exacerbation and Human Exposure - Utilities	
Due Care Design, Engineering, Management and Coordination	
Act 381 Work Plans and Implementation (x2)⁽²⁾	\$90,000
Subtotal Department Specific Activities	\$890,000
Contingency (10%)	\$120,000
Total Department Specific Activities	\$1,010,000
ELIGIBLE NON-ENVIRONMENTAL (MSF) ACTIVITIES⁽¹⁾	
Demolition Activities	
Pavement and drainage structure removal	\$1,260,000
Public Infrastructure Improvements - Roadway Improvements	
Roadway Reconstruction	
Railroad Crossing Improvements	
Bridge Repairs and Replacement	
Stormwater Management	
Traffic Control and Signage	
Utility/Power Pole Relocation	
Geotechnical Engineering	
Architectural and Engineering Design, and Surveying/Staking Services	
Site Construction Management	
Construction General Conditions	\$15,282,225
Public Infrastructure Improvements - Sanitary Sewer	
Excavation and Earthwork	
Dewatering	
Install Upgraded Sewer	
Construct Pump Station	
Install Back-up Generator	
Site Restoration	
Geotechnical Engineering	
Architectural and Engineering Design, and Surveying/Staking Services	
Site Construction Management	
Construction General Conditions	\$3,178,350
Public Infrastructure Improvements - Water Main	
Excavation and Earthwork	
Dewatering	
Install Upgraded Water Main	
Construct Water Storage Tank	
Roadway and Site Restoration	
Architectural and Engineering Design, and Surveying/Staking Services	
Site Construction Management	
Construction General Conditions	\$6,029,910
Public Infrastructure Improvements	
Western Storm Water Management System	\$400,000
Act 381 Work Plans and Implementation (x2)⁽²⁾	\$90,000
Subtotal Department Specific Activities	\$26,240,485
Contingency (10%)	\$2,615,049
Total Non-Environmental Activities	\$28,855,534
TOTAL ELIGIBLE ACTIVITIES⁽³⁾	\$29,865,534

Notes:

⁽¹⁾ Cost estimates are based on engineering, contractor, or developer estimates or consultant experience.

⁽²⁾ These costs are not included in the contingency calculation.



**TABLE 1-4
BROWNFIELD ELIGIBLE ACTIVITIES COST SUMMARY
Northville Lumber**

5/13/2023

ELIGIBLE ACTIVITIES	TOTAL ELIGIBLE COST
ELIGIBLE DEPARTMENT SPECIFIC (EGLE) ACTIVITIES⁽¹⁾	
BEA Activities Phase I ESA Phase II ESA BEA Report	\$45,765
Due Care Activities Due Care Planning and Coordination Due Care Plans and Documentation Remediation of Contaminated Soil Prevention of Human Exposure and Exacerbation - Utilities Dust, Runoff, and Track-out Control Field Monitoring and Project Management Due Care Design, Engineering, Management and Coordination Architectural and Engineering Design Site Construction Management Construction General Conditions	\$1,633,280
Brownfield Plan, Act 381 Work Plan, and Implementation⁽²⁾	\$30,000
Subtotal Department Specific Activities	\$1,709,045
Contingency (15%)	\$237,792
Total Department Specific Activities	\$1,946,837
MSF ELIGIBLE (NON-ENVIRONMENTAL) ACTIVITIES⁽¹⁾	
Demolition Activities Remnant Foundations and Utilities Removal	\$56,500
Public Infrastructure Improvements ROW and Site Access Improvements Architectural and Engineering Design Site Construction Management Construction General Conditions	\$467,988
Site Preparation Activities Clearing and Grubbing Temporary Facilities Surveying and Staking Site Grading and Balancing Imported Fill for Site Balancing Utility Relocation Onsite Field Monitoring and Project Management Architectural and Engineering Design Site Construction Management Construction General Conditions	\$895,759
Brownfield Plan, Act 381 Work Plan, and Implementation⁽²⁾	\$30,000
Subtotal Department Specific Activities	\$1,450,247
Contingency (15%)	\$213,037
Total MSF Eligible Activities	\$1,663,284
TOTAL ELIGIBLE ACTIVITIES	\$3,610,121

Notes:

⁽¹⁾ Cost estimates are based on consultant, engineering, contractor, or developer estimates.

⁽²⁾ These costs are not included in the contingency calculation.

APPENDIX B

TABLE 2-1 SUMMARY OF TIR CAPTURE FOR PARCEL 13

TABLE 2-2 SUMMARY OF TIR CAPTURE FOR PARCEL 11/12

TABLE 2-2 SUMMARY OF TIR CAPTURE FOR PARCEL ((NORTHVILLE LUMBER CO. PORTION)



Table 2-1
TAX INCREMENT REVENUE
Parcel 13
MITC Redevelopment Area
Plymouth Township, Michigan
2/23/2022

Estimated Taxable Value (TV) Increase Rate: 2% per year

Plan Year	5	6	7	8	9	10	11	12	13	14	15	16	17	18	19	20	
Calendar Year	2023	2024	2025	2026	2027	2028	2029	2030	2031	2032	2033	2034	2035	2036	2037	2038	
*Base Taxable Value																	
Estimated New TV ¹	\$ 2,846,680	\$ 2,903,614	\$ 2,961,686	\$ 3,020,920	\$ 3,081,338	\$ 3,142,965	\$ 3,205,824	\$ 3,269,941	\$ 3,335,339	\$ 3,402,046	\$ 3,470,087	\$ 3,539,489	\$ 3,610,279	\$ 3,682,484	\$ 3,756,134	\$ 3,831,256	
Land & Bldg Incremental Difference (New TV - Base TV)	\$ 2,846,680	\$ 2,903,614	\$ 2,961,686	\$ 3,020,920	\$ 3,081,338	\$ 3,142,965	\$ 3,205,824	\$ 3,269,941	\$ 3,335,339	\$ 3,402,046	\$ 3,470,087	\$ 3,539,489	\$ 3,610,279	\$ 3,682,484	\$ 3,756,134	\$ 3,831,256	
	41.4026																
	9.3273																
School Capture	Millage Rate	SLBA 5/50															
State Education Tax (SET)	6.0000	\$ 8,540	\$ 17,422	\$ 17,770	\$ 18,126	\$ 18,488	\$ 18,858	\$ 19,235	\$ 19,620	\$ 20,012	\$ 20,412	\$ 20,821	\$ 21,237	\$ 21,662	\$ 22,095	\$ 22,537	\$ 22,988
School Operating Tax	18.0000	\$ 25,620	\$ 52,265	\$ 53,310	\$ 54,377	\$ 55,464	\$ 56,573	\$ 57,705	\$ 58,859	\$ 60,036	\$ 61,237	\$ 62,462	\$ 63,711	\$ 64,985	\$ 66,285	\$ 67,610	\$ 68,963
School Total	24.0000	\$ 34,160	\$ 69,687	\$ 71,080	\$ 72,503	\$ 73,952	\$ 75,431	\$ 76,940	\$ 78,479	\$ 80,048	\$ 81,649	\$ 83,283	\$ 84,948	\$ 86,647	\$ 88,380	\$ 90,147	\$ 91,951
Local Capture	Millage Rate																
Township (winter)	0.8103	\$ 1,154	\$ 2,353	\$ 2,400	\$ 2,448	\$ 2,497	\$ 2,547	\$ 2,598	\$ 2,650	\$ 2,703	\$ 2,757	\$ 2,812	\$ 2,868	\$ 2,925	\$ 2,984	\$ 3,044	\$ 3,104
Police-Fire (1) (winter)	1.6211	\$ 2,308	\$ 4,707	\$ 4,801	\$ 4,897	\$ 4,995	\$ 5,095	\$ 5,197	\$ 5,301	\$ 5,407	\$ 5,515	\$ 5,625	\$ 5,738	\$ 5,853	\$ 5,970	\$ 6,089	\$ 6,211
Police-Fire (2) (winter)	0.5583	\$ 795	\$ 1,621	\$ 1,654	\$ 1,687	\$ 1,720	\$ 1,755	\$ 1,790	\$ 1,826	\$ 1,862	\$ 1,899	\$ 1,937	\$ 1,976	\$ 2,016	\$ 2,056	\$ 2,097	\$ 2,139
Police-Fire (3) (winter)	1.1926	\$ 1,698	\$ 3,463	\$ 3,532	\$ 3,603	\$ 3,675	\$ 3,748	\$ 3,823	\$ 3,900	\$ 3,978	\$ 4,057	\$ 4,138	\$ 4,221	\$ 4,306	\$ 4,392	\$ 4,480	\$ 4,569
Fire (Winter)	0.9866	\$ 1,405	\$ 2,865	\$ 2,922	\$ 2,980	\$ 3,040	\$ 3,101	\$ 3,163	\$ 3,226	\$ 3,291	\$ 3,356	\$ 3,424	\$ 3,492	\$ 3,562	\$ 3,633	\$ 3,706	\$ 3,780
Wayne County (winter)	0.9897	\$ 1,409	\$ 2,874	\$ 2,931	\$ 2,990	\$ 3,050	\$ 3,111	\$ 3,173	\$ 3,236	\$ 3,301	\$ 3,367	\$ 3,434	\$ 3,503	\$ 3,573	\$ 3,645	\$ 3,717	\$ 3,792
Wayne County Jail (winter)	0.9381	\$ 1,335	\$ 2,724	\$ 2,778	\$ 2,834	\$ 2,891	\$ 2,948	\$ 3,007	\$ 3,068	\$ 3,129	\$ 3,191	\$ 3,255	\$ 3,320	\$ 3,387	\$ 3,455	\$ 3,524	\$ 3,594
Wayne County Parks (winter)	0.2459	\$ 350	\$ 714	\$ 728	\$ 743	\$ 758	\$ 773	\$ 788	\$ 804	\$ 820	\$ 837	\$ 853	\$ 870	\$ 888	\$ 906	\$ 924	\$ 942
HCMA (winter)	0.2104	\$ 300	\$ 611	\$ 623	\$ 636	\$ 648	\$ 661	\$ 675	\$ 688	\$ 702	\$ 716	\$ 730	\$ 745	\$ 760	\$ 775	\$ 790	\$ 806
Plymouth Library (winter)	1.4448	\$ 2,057	\$ 4,195	\$ 4,279	\$ 4,365	\$ 4,452	\$ 4,541	\$ 4,632	\$ 4,724	\$ 4,819	\$ 4,915	\$ 5,014	\$ 5,114	\$ 5,216	\$ 5,320	\$ 5,427	\$ 5,535
Community College (winter)	0.0177	\$ 25	\$ 51	\$ 52	\$ 53	\$ 55	\$ 56	\$ 57	\$ 58	\$ 59	\$ 60	\$ 61	\$ 63	\$ 64	\$ 65	\$ 66	\$ 68
Community College (summer)	2.2700	\$ 3,231	\$ 6,591	\$ 6,723	\$ 6,857	\$ 6,995	\$ 7,135	\$ 7,277	\$ 7,423	\$ 7,571	\$ 7,723	\$ 7,877	\$ 8,035	\$ 8,195	\$ 8,359	\$ 8,526	\$ 8,697
RESA - Spec Ed (summer)	3.3678	\$ 4,794	\$ 9,779	\$ 9,974	\$ 10,174	\$ 10,377	\$ 10,585	\$ 10,797	\$ 11,013	\$ 11,233	\$ 11,457	\$ 11,687	\$ 11,920	\$ 12,159	\$ 12,402	\$ 12,650	\$ 12,903
RESA - Gen Operating (summer)	0.0965	\$ 138	\$ 280	\$ 286	\$ 292	\$ 297	\$ 303	\$ 309	\$ 316	\$ 322	\$ 328	\$ 335	\$ 342	\$ 348	\$ 355	\$ 362	\$ 370
RESA - Enhance (summer)	2.0000	\$ 2,847	\$ 5,807	\$ 5,923	\$ 6,042	\$ 6,163	\$ 6,286	\$ 6,412	\$ 6,540	\$ 6,671	\$ 6,804	\$ 6,940	\$ 7,079	\$ 7,221	\$ 7,365	\$ 7,512	\$ 7,663
Wayne County (Summer)	5.6483	\$ 8,040	\$ 16,400	\$ 16,728	\$ 17,063	\$ 17,404	\$ 17,752	\$ 18,107	\$ 18,470	\$ 18,839	\$ 19,216	\$ 19,600	\$ 19,992	\$ 20,392	\$ 20,800	\$ 21,216	\$ 21,640
Local Total	22.3981	\$ 31,880	\$ 65,035	\$ 66,334	\$ 67,664	\$ 69,017	\$ 70,397	\$ 71,805	\$ 73,243	\$ 74,707	\$ 76,198	\$ 77,722	\$ 79,278	\$ 80,865	\$ 82,482	\$ 84,130	\$ 85,813
Non-Capturable Millages	Millage Rate																
School Debt (summer)	4.0200	\$ 5,722	\$ 5,837	\$ 5,953	\$ 6,072	\$ 6,194	\$ 6,318	\$ 6,444	\$ 6,571	\$ 6,700	\$ 6,830	\$ 6,961	\$ 7,094	\$ 7,229	\$ 7,365	\$ 7,503	\$ 7,642
Wayne County Art Institute (winter)	0.2000	\$ 285	\$ 291	\$ 296	\$ 302	\$ 308	\$ 315	\$ 321	\$ 327	\$ 334	\$ 340	\$ 347	\$ 354	\$ 361	\$ 368	\$ 376	\$ 383
Wayne County Zoo	0.1000	\$ 143	\$ 145	\$ 148	\$ 151	\$ 154	\$ 157	\$ 161	\$ 164	\$ 167	\$ 170	\$ 173	\$ 176	\$ 179	\$ 182	\$ 185	\$ 188
Total Non-Capturable Taxes	4.3200	\$ 6,149	\$ 6,272	\$ 6,397	\$ 6,525	\$ 6,656	\$ 6,789	\$ 6,925	\$ 7,064	\$ 7,205	\$ 7,348	\$ 7,494	\$ 7,642	\$ 7,792	\$ 7,944	\$ 8,098	\$ 8,254
Total Tax Increment Revenue (TIR) Available for Capture		\$ 66,040	\$ 134,722	\$ 137,414	\$ 140,167	\$ 142,969	\$ 145,828	\$ 148,745	\$ 151,722	\$ 154,755	\$ 157,847	\$ 161,005	\$ 164,226	\$ 167,512	\$ 170,862	\$ 174,277	\$ 177,764



Table 2-1
TAX INCREMENT REVENUE
Parcel 13
MITC Redevelopment Area
Plymouth Township, Michigan
2/23/2022

Estimated Taxable Value (TV) Increase Rate:

Plan Year Calendar Year	21	22	23	24	25	26	27	28	29	30	TOTAL	
	2039	2040	2041	2042	2043	2044	2045	2046	2047	2048		
*Base Taxable Value												
Estimated New TV ¹	\$ 3,907,882	\$ 3,986,039	\$ 4,065,760	\$ 4,147,075	\$ 4,230,017	\$ 4,314,617	\$ 4,400,909	\$ 4,488,928	\$ 4,578,706	\$ 4,670,280		
Land & Bldg Incremental Difference (New TV - Base TV)	\$ 3,907,882	\$ 3,986,039	\$ 4,065,760	\$ 4,147,075	\$ 4,230,017	\$ 4,314,617	\$ 4,400,909	\$ 4,488,928	\$ 4,578,706	\$ 4,670,280		
41.4026												
9.3273												
School Capture												
	Millage Rate											
State Education Tax (SET)	6.0000	\$ 23,447	\$ 23,916	\$ 24,395	\$ 24,882	\$ 25,380	\$ 25,888	\$ 26,405	\$ 26,934	\$ 27,472	\$ 28,022	\$ 566,564
School Operating Tax	18.0000	\$ 70,342	\$ 71,749	\$ 73,184	\$ 74,647	\$ 76,140	\$ 77,663	\$ 79,216	\$ 80,801	\$ 82,417	\$ 84,065	\$ 1,699,686
School Total	24.0000	\$ 93,789	\$ 95,665	\$ 97,579	\$ 99,529	\$ 101,520	\$ 103,551	\$ 105,621	\$ 107,735	\$ 109,889	\$ 112,087	\$ 2,266,250
Local Capture												
	Millage Rate											
Township (winter)	0.8103	\$ 3,167	\$ 3,230	\$ 3,294	\$ 3,360	\$ 3,428	\$ 3,496	\$ 3,566	\$ 3,637	\$ 3,710	\$ 3,784	\$ 76,516
Police-Fire (1) (winter)	1.6211	\$ 6,335	\$ 6,462	\$ 6,591	\$ 6,723	\$ 6,857	\$ 6,994	\$ 7,134	\$ 7,277	\$ 7,423	\$ 7,571	\$ 153,076
Police-Fire (2) (winter)	0.5583	\$ 2,182	\$ 2,225	\$ 2,270	\$ 2,315	\$ 2,362	\$ 2,409	\$ 2,457	\$ 2,506	\$ 2,556	\$ 2,607	\$ 52,719
Police-Fire (3) (winter)	1.1926	\$ 4,661	\$ 4,754	\$ 4,849	\$ 4,946	\$ 5,045	\$ 5,146	\$ 5,249	\$ 5,353	\$ 5,461	\$ 5,570	\$ 112,617
Fire (Winter)	0.9866	\$ 3,856	\$ 3,933	\$ 4,011	\$ 4,092	\$ 4,173	\$ 4,257	\$ 4,342	\$ 4,429	\$ 4,517	\$ 4,608	\$ 93,164
Wayne County (winter)	0.9897	\$ 3,868	\$ 3,945	\$ 4,024	\$ 4,104	\$ 4,186	\$ 4,270	\$ 4,356	\$ 4,443	\$ 4,532	\$ 4,622	\$ 93,456
Wayne County Jail (winter)	0.9381	\$ 3,666	\$ 3,739	\$ 3,814	\$ 3,890	\$ 3,968	\$ 4,048	\$ 4,128	\$ 4,211	\$ 4,295	\$ 4,381	\$ 88,580
Wayne County Parks (winter)	0.2459	\$ 961	\$ 980	\$ 1,000	\$ 1,020	\$ 1,040	\$ 1,061	\$ 1,082	\$ 1,104	\$ 1,126	\$ 1,148	\$ 23,220
HCMA (winter)	0.2104	\$ 822	\$ 839	\$ 855	\$ 873	\$ 890	\$ 908	\$ 926	\$ 944	\$ 963	\$ 983	\$ 19,869
Plymouth Library (winter)	1.4448	\$ 5,646	\$ 5,759	\$ 5,874	\$ 5,992	\$ 6,112	\$ 6,234	\$ 6,358	\$ 6,486	\$ 6,615	\$ 6,748	\$ 136,429
Community College (winter)	0.0177	\$ 69	\$ 71	\$ 72	\$ 73	\$ 75	\$ 76	\$ 78	\$ 79	\$ 81	\$ 83	\$ 1,670
Community College (summer)	2.2700	\$ 8,871	\$ 9,048	\$ 9,229	\$ 9,414	\$ 9,602	\$ 9,794	\$ 9,990	\$ 10,190	\$ 10,394	\$ 10,602	\$ 214,349
RESA - Spec Ed (summer)	3.3678	\$ 13,161	\$ 13,424	\$ 13,693	\$ 13,967	\$ 14,246	\$ 14,531	\$ 14,821	\$ 15,118	\$ 15,420	\$ 15,729	\$ 318,014
RESA - Gen Operating (summer)	0.0965	\$ 377	\$ 385	\$ 392	\$ 400	\$ 408	\$ 416	\$ 425	\$ 433	\$ 442	\$ 451	\$ 9,112
RESA - Enhance (summer)	2.0000	\$ 7,816	\$ 7,972	\$ 8,132	\$ 8,294	\$ 8,460	\$ 8,629	\$ 8,802	\$ 8,978	\$ 9,157	\$ 9,341	\$ 188,856
Wayne County (Summer)	5.6483	\$ 22,073	\$ 22,514	\$ 22,965	\$ 23,424	\$ 23,892	\$ 24,370	\$ 24,858	\$ 25,355	\$ 25,862	\$ 26,379	\$ 533,351
Local Total	22.3981	\$ 87,531	\$ 89,280	\$ 91,065	\$ 92,887	\$ 94,744	\$ 96,639	\$ 98,572	\$ 100,543	\$ 102,554	\$ 104,607	\$ 2,114,992
Non-Capturable Millages												
	Millage Rate											
School Debt (summer)	4.0200	\$ 15,710	\$ 16,024	\$ 16,344	\$ 16,671	\$ 17,005	\$ 17,345	\$ 17,692	\$ 18,045	\$ 18,406	\$ 18,775	\$ 342,782
Wayne County Art Institute (winter)	0.2000	\$ 782	\$ 797	\$ 813	\$ 829	\$ 846	\$ 863	\$ 880	\$ 898	\$ 916	\$ 934	\$ 17,052
Wayne County Zoo	0.1000	\$ 391	\$ 399	\$ 407	\$ 415	\$ 423	\$ 431	\$ 440	\$ 449	\$ 458	\$ 467	\$ 8,528
Total Non-Capturable Taxes	4.3200	\$ 16,883	\$ 17,220	\$ 17,564	\$ 17,915	\$ 18,274	\$ 18,639	\$ 19,012	\$ 19,392	\$ 19,780	\$ 20,176	\$ 368,362
Total Tax Increment Revenue (TIR) Available for Capture		\$ 181,320	\$ 184,945	\$ 188,644	\$ 192,416	\$ 196,264	\$ 200,190	\$ 204,193	\$ 208,278	\$ 212,443	\$ 216,694	\$ 4,381,242



Table 2-2
TAX INCREMENT REVENUE
Parcel 11/12 - Ridge 5 Corporate Park
MITC Redevelopment Area
Plymouth Township, Michigan
2/23/2022

Estimated Taxable Value (TV) Increase Rate: 2% per year

Plan Year	Calendar Year																			
	3	4	5	6	7	8	9	10	11	12	13	14	15	16	17	18	19			
*Base Taxable Value	\$ -	\$ -	\$ -	\$ -	\$ -	\$ -	\$ -	\$ -	\$ -	\$ -	\$ -	\$ -	\$ -	\$ -	\$ -	\$ -	\$ -	\$ -		
Estimated New TV ¹	\$ 3,000,000	\$ 10,500,000	\$ 16,500,000	\$ 21,000,000	\$ 25,500,000	\$ 27,000,000	\$ 30,000,000	\$ 30,600,000	\$ 31,212,000	\$ 31,836,240	\$ 32,472,965	\$ 33,122,424	\$ 33,784,872	\$ 34,460,569	\$ 35,149,780	\$ 35,852,776	\$ 36,569,832			
Incremental Difference (New TV - Base TV)	\$ 3,000,000	\$ 10,500,000	\$ 16,500,000	\$ 21,000,000	\$ 25,500,000	\$ 27,000,000	\$ 30,000,000	\$ 30,600,000	\$ 31,212,000	\$ 31,836,240	\$ 32,472,965	\$ 33,122,424	\$ 33,784,872	\$ 34,460,569	\$ 35,149,780	\$ 35,852,776	\$ 36,569,832			
School Capture		Millage Rate																		
State Education Tax (SET)	6.0000	\$ 18,000	\$ 63,000	\$ 99,000	\$ 126,000	\$ 153,000	\$ 162,000	\$ 180,000	\$ 183,600	\$ 187,272	\$ 191,017	\$ 194,838	\$ 198,735	\$ 202,709	\$ 206,763	\$ 210,899	\$ 215,117	\$ 219,419		
School Operating	18.0000	\$ 54,000	\$ 189,000	\$ 297,000	\$ 378,000	\$ 459,000	\$ 486,000	\$ 540,000	\$ 550,800	\$ 561,816	\$ 573,052	\$ 584,513	\$ 596,204	\$ 608,128	\$ 620,290	\$ 632,696	\$ 645,350	\$ 658,257		
School Total	24.0000	\$ 72,000	\$ 252,000	\$ 396,000	\$ 504,000	\$ 612,000	\$ 648,000	\$ 720,000	\$ 734,400	\$ 749,088	\$ 764,069	\$ 779,351	\$ 794,939	\$ 810,837	\$ 827,053	\$ 843,595	\$ 860,467	\$ 877,676		
Local Capture		Millage Rate																		
Township	0.8134	\$ 2,440	\$ 8,541	\$ 13,421	\$ 17,081	\$ 20,742	\$ 21,962	\$ 24,402	\$ 24,890	\$ 25,388	\$ 25,896	\$ 26,414	\$ 26,942	\$ 27,481	\$ 28,030	\$ 28,591	\$ 29,163	\$ 29,746		
Police-Fire (1)	1.6272	\$ 4,882	\$ 17,086	\$ 26,849	\$ 34,171	\$ 41,494	\$ 43,934	\$ 48,816	\$ 49,792	\$ 50,788	\$ 51,804	\$ 52,840	\$ 53,897	\$ 54,975	\$ 56,074	\$ 57,196	\$ 58,340	\$ 59,506		
Police-Fire (2)	0.5604	\$ 1,681	\$ 5,884	\$ 9,247	\$ 11,768	\$ 14,290	\$ 15,131	\$ 16,812	\$ 17,148	\$ 17,491	\$ 17,841	\$ 18,198	\$ 18,562	\$ 18,933	\$ 19,312	\$ 19,698	\$ 20,092	\$ 20,494		
Police-Fire (3)	1.1971	\$ 3,591	\$ 12,570	\$ 19,752	\$ 25,139	\$ 30,526	\$ 32,322	\$ 35,913	\$ 36,631	\$ 37,364	\$ 38,111	\$ 38,873	\$ 39,651	\$ 40,444	\$ 41,253	\$ 42,078	\$ 42,919	\$ 43,778		
Fire	0.9903	\$ 2,971	\$ 10,398	\$ 16,340	\$ 20,796	\$ 25,253	\$ 26,738	\$ 29,709	\$ 30,303	\$ 30,909	\$ 31,527	\$ 32,158	\$ 32,801	\$ 33,457	\$ 34,126	\$ 34,809	\$ 35,505	\$ 36,215		
Plymouth Library	1.4535	\$ 4,361	\$ 15,262	\$ 23,983	\$ 30,524	\$ 37,064	\$ 39,245	\$ 43,605	\$ 44,477	\$ 45,367	\$ 46,274	\$ 47,199	\$ 48,143	\$ 49,106	\$ 50,088	\$ 51,090	\$ 52,112	\$ 53,154		
Wayne County	5.6483	\$ 16,945	\$ 59,307	\$ 93,197	\$ 118,614	\$ 144,032	\$ 152,504	\$ 169,449	\$ 172,838	\$ 176,295	\$ 179,821	\$ 183,417	\$ 187,085	\$ 190,827	\$ 194,644	\$ 198,537	\$ 202,507	\$ 206,557		
Wayne County	0.9897	\$ 2,969	\$ 10,392	\$ 16,330	\$ 20,784	\$ 25,237	\$ 26,722	\$ 29,691	\$ 30,285	\$ 30,891	\$ 31,508	\$ 32,138	\$ 32,781	\$ 33,437	\$ 34,106	\$ 34,788	\$ 35,483	\$ 36,193		
WC Jail	0.9381	\$ 2,814	\$ 9,850	\$ 15,479	\$ 19,700	\$ 23,922	\$ 25,329	\$ 28,143	\$ 28,706	\$ 29,280	\$ 29,866	\$ 30,463	\$ 31,072	\$ 31,694	\$ 32,327	\$ 32,974	\$ 33,633	\$ 34,306		
WC Parks	0.2459	\$ 738	\$ 2,582	\$ 4,057	\$ 5,164	\$ 6,270	\$ 6,639	\$ 7,377	\$ 7,525	\$ 7,675	\$ 7,829	\$ 7,985	\$ 8,145	\$ 8,308	\$ 8,474	\$ 8,643	\$ 8,816	\$ 8,993		
HCMA	0.2117	\$ 635	\$ 2,223	\$ 3,493	\$ 4,446	\$ 5,398	\$ 5,716	\$ 6,351	\$ 6,478	\$ 6,608	\$ 6,740	\$ 6,875	\$ 7,012	\$ 7,152	\$ 7,295	\$ 7,441	\$ 7,590	\$ 7,742		
Community College	2.2516	\$ 6,755	\$ 23,642	\$ 37,151	\$ 47,284	\$ 57,416	\$ 60,793	\$ 67,548	\$ 68,899	\$ 70,277	\$ 71,682	\$ 73,116	\$ 74,578	\$ 76,070	\$ 77,591	\$ 79,143	\$ 80,726	\$ 82,341		
RESA - Spec Ed	3.3678	\$ 10,103	\$ 35,362	\$ 55,569	\$ 70,724	\$ 85,879	\$ 90,931	\$ 101,034	\$ 103,055	\$ 105,116	\$ 107,218	\$ 109,362	\$ 111,550	\$ 113,781	\$ 116,056	\$ 118,377	\$ 120,745	\$ 123,160		
RESA - Gen Oper	0.0965	\$ 290	\$ 1,013	\$ 1,592	\$ 2,027	\$ 2,461	\$ 2,606	\$ 2,895	\$ 2,953	\$ 3,012	\$ 3,072	\$ 3,134	\$ 3,196	\$ 3,260	\$ 3,325	\$ 3,392	\$ 3,460	\$ 3,529		
RESA - Enhance	2.0000	\$ 6,000	\$ 21,000	\$ 33,000	\$ 42,000	\$ 51,000	\$ 54,000	\$ 60,000	\$ 61,200	\$ 62,424	\$ 63,672	\$ 64,946	\$ 66,245	\$ 67,570	\$ 68,921	\$ 70,300	\$ 71,706	\$ 73,140		
Local Total	22.3915	\$ 67,175	\$ 235,112	\$ 369,460	\$ 470,222	\$ 570,984	\$ 604,572	\$ 671,745	\$ 685,180	\$ 698,885	\$ 712,861	\$ 727,118	\$ 741,660	\$ 756,495	\$ 771,622	\$ 787,057	\$ 802,797	\$ 818,854		
Non-Capturable Millages		Millage Rate																		
WC Zoo	0.1000	\$ 300	\$ 1,050	\$ 825	\$ 1,050	\$ 1,275	\$ 1,350	\$ 1,500	\$ 1,530	\$ 1,680	\$ 1,710	\$ 1,860	\$ 1,890	\$ 2,040	\$ 2,070	\$ 2,220	\$ 2,250	\$ 2,400		
WC Art Institute	0.2000	\$ 600	\$ 2,100	\$ 1,650	\$ 2,100	\$ 2,550	\$ 2,700	\$ 3,000	\$ 3,060	\$ 3,360	\$ 3,420	\$ 3,720	\$ 3,780	\$ 4,080	\$ 4,140	\$ 4,440	\$ 4,500	\$ 4,800		
School Debt	4.0200	\$ 12,060	\$ 42,210	\$ 33,165	\$ 42,210	\$ 51,255	\$ 54,270	\$ 60,300	\$ 61,506	\$ 62,712	\$ 63,918	\$ 65,124	\$ 66,330	\$ 67,536	\$ 68,742	\$ 70,000	\$ 71,250	\$ 72,500		
Total Non-Capturable Taxes	4.3200	\$ 12,960	\$ 45,360	\$ 35,640	\$ 45,360	\$ 55,080	\$ 58,320	\$ 64,800	\$ 66,096	\$ 67,392	\$ 68,688	\$ 69,984	\$ 71,280	\$ 72,576	\$ 73,872	\$ 75,168	\$ 76,464	\$ 77,760		
Total Tax Increment Revenue (TIR) Available for Capture		\$ 139,175	\$ 487,112	\$ 765,460	\$ 974,222	\$ 1,182,984	\$ 1,252,572	\$ 1,391,745	\$ 1,419,580	\$ 1,447,973	\$ 1,476,930	\$ 1,506,469	\$ 1,536,599	\$ 1,567,332	\$ 1,598,675	\$ 1,630,652	\$ 1,663,264	\$ 1,696,530		



Table 2-2
TAX INCREMENT REVENUE
Parcel 11/12 - Ridge 5 Corporate Park
MITC Redevelopment Area
Plymouth Township, Michigan
2/23/2022

Estimated Taxable Value (TV) Increase Rate:

Plan Year	Calendar Year	20	21	22	23	24	25	26	27	28	29	30	TOTAL
		2038	2039	2040	2041	2042	2043	2044	2045	2046	2047	2048	
*Base Taxable Value		\$ -	\$ -	\$ -	\$ -	\$ -	\$ -	\$ -	\$ -	\$ -	\$ -	\$ -	
Estimated New TV ¹		\$ 37,301,229	\$ 38,047,254	\$ 38,808,199	\$ 39,584,363	\$ 40,376,050	\$ 41,183,571	\$ 42,007,242	\$ 42,847,387	\$ 43,704,335	\$ 44,578,422	\$ 45,469,990	
Incremental Difference (New TV - Base TV)		\$ 37,301,229	\$ 38,047,254	\$ 38,808,199	\$ 39,584,363	\$ 40,376,050	\$ 41,183,571	\$ 42,007,242	\$ 42,847,387	\$ 43,704,335	\$ 44,578,422	\$ 45,469,990	
School Capture		Millage Rate											
State Education Tax (SET)	6.0000	\$ 223,807	\$ 228,284	\$ 232,849	\$ 237,506	\$ 242,256	\$ 247,101	\$ 252,043	\$ 257,084	\$ 262,226	\$ 267,471	\$ 272,820	\$ 5,534,816
School Operating	18.0000	\$ 671,422	\$ 684,851	\$ 698,548	\$ 712,519	\$ 726,769	\$ 741,304	\$ 756,130	\$ 771,253	\$ 786,678	\$ 802,412	\$ 818,460	\$ 16,604,452
School Total	24.0000	\$ 895,229	\$ 913,135	\$ 931,397	\$ 950,025	\$ 969,025	\$ 988,405	\$ 1,008,173	\$ 1,028,337	\$ 1,048,904	\$ 1,069,883	\$ 1,091,280	\$ 22,139,268
Local Capture		Millage Rate											
Township	0.8134	\$ 30,341	\$ 30,948	\$ 31,567	\$ 32,198	\$ 32,842	\$ 33,499	\$ 34,169	\$ 34,852	\$ 35,549	\$ 36,260	\$ 36,985	\$ 750,340
Police-Fire (1)	1.6272	\$ 60,697	\$ 61,910	\$ 63,149	\$ 64,412	\$ 65,700	\$ 67,014	\$ 68,354	\$ 69,721	\$ 71,116	\$ 72,538	\$ 73,989	\$ 1,501,044
Police-Fire (2)	0.5604	\$ 20,904	\$ 21,322	\$ 21,748	\$ 22,183	\$ 22,627	\$ 23,079	\$ 23,541	\$ 24,012	\$ 24,492	\$ 24,982	\$ 25,481	\$ 516,953
Police-Fire (3)	1.1971	\$ 44,653	\$ 45,546	\$ 46,457	\$ 47,386	\$ 48,334	\$ 49,301	\$ 50,287	\$ 51,293	\$ 52,318	\$ 53,365	\$ 54,432	\$ 1,104,287
Fire	0.9903	\$ 36,939	\$ 37,678	\$ 38,432	\$ 39,200	\$ 39,984	\$ 40,784	\$ 41,600	\$ 42,432	\$ 43,280	\$ 44,146	\$ 45,029	\$ 913,519
Plymouth Library	1.4535	\$ 54,217	\$ 55,302	\$ 56,408	\$ 57,536	\$ 58,687	\$ 59,860	\$ 61,058	\$ 62,279	\$ 63,524	\$ 64,795	\$ 66,091	\$ 1,340,811
Wayne County	5.6483	\$ 210,689	\$ 214,902	\$ 219,200	\$ 223,584	\$ 228,056	\$ 232,617	\$ 237,270	\$ 242,015	\$ 246,855	\$ 251,792	\$ 256,828	\$ 5,210,384
Wayne County	0.9897	\$ 36,917	\$ 37,655	\$ 38,408	\$ 39,177	\$ 39,960	\$ 40,759	\$ 41,575	\$ 42,406	\$ 43,254	\$ 44,119	\$ 45,002	\$ 912,967
WC Jail	0.9381	\$ 34,992	\$ 35,692	\$ 36,406	\$ 37,134	\$ 37,877	\$ 38,634	\$ 39,407	\$ 40,195	\$ 40,999	\$ 41,819	\$ 42,655	\$ 865,368
WC Parks	0.2459	\$ 9,172	\$ 9,356	\$ 9,543	\$ 9,734	\$ 9,928	\$ 10,127	\$ 10,330	\$ 10,536	\$ 10,747	\$ 10,962	\$ 11,181	\$ 226,836
HCMA	0.2117	\$ 7,897	\$ 8,055	\$ 8,216	\$ 8,380	\$ 8,548	\$ 8,719	\$ 8,893	\$ 9,071	\$ 9,252	\$ 9,437	\$ 9,626	\$ 195,289
Community College	2.2516	\$ 83,987	\$ 85,667	\$ 87,381	\$ 89,128	\$ 90,911	\$ 92,729	\$ 94,584	\$ 96,475	\$ 98,405	\$ 100,373	\$ 102,380	\$ 2,077,032
RESA - Spec Ed	3.3678	\$ 125,623	\$ 128,136	\$ 130,698	\$ 133,312	\$ 135,978	\$ 138,698	\$ 141,472	\$ 144,301	\$ 147,187	\$ 150,131	\$ 153,134	\$ 3,106,692
RESA - Gen Oper	0.0965	\$ 3,600	\$ 3,672	\$ 3,745	\$ 3,820	\$ 3,896	\$ 3,974	\$ 4,054	\$ 4,135	\$ 4,217	\$ 4,302	\$ 4,388	\$ 89,020
RESA - Enhance	2.0000	\$ 74,602	\$ 76,095	\$ 77,616	\$ 79,169	\$ 80,752	\$ 82,367	\$ 84,014	\$ 85,695	\$ 87,409	\$ 89,157	\$ 90,940	\$ 1,844,940
Local Total	22.3915	\$ 835,230	\$ 851,936	\$ 868,974	\$ 886,353	\$ 904,080	\$ 922,161	\$ 940,608	\$ 959,418	\$ 978,604	\$ 998,178	\$ 1,018,141	\$ 20,655,482
Non-Capturable Millages		Millage Rate											
WC Zoo	0.1000	\$ 3,730	\$ 3,805	\$ 3,881	\$ 3,958	\$ 4,038	\$ 4,118	\$ 4,201	\$ 4,285	\$ 4,370	\$ 4,458	\$ 4,547	\$ 84,716
WC Art Institute	0.2000	\$ 7,460	\$ 7,609	\$ 7,762	\$ 7,917	\$ 8,075	\$ 8,237	\$ 8,401	\$ 8,569	\$ 8,741	\$ 8,916	\$ 9,094	\$ 169,433
School Debt	4.0200	\$ 149,951	\$ 152,950	\$ 156,009	\$ 159,129	\$ 162,312	\$ 165,558	\$ 168,869	\$ 172,246	\$ 175,691	\$ 179,205	\$ 182,789	\$ 3,405,619
Total Non-Capturable Taxes	4.3200	\$ 161,141	\$ 164,364	\$ 167,652	\$ 171,004	\$ 174,425	\$ 177,913	\$ 181,471	\$ 185,100	\$ 188,802	\$ 192,579	\$ 196,430	\$ 3,659,768
Total Tax Increment Revenue (TIR) Available for Capture		\$ 1,730,459	\$ 1,765,071	\$ 1,800,371	\$ 1,836,378	\$ 1,873,105	\$ 1,910,566	\$ 1,948,781	\$ 1,987,755	\$ 2,027,508	\$ 2,068,061	\$ 2,109,421	\$ 42,794,750



Table 2-3
TAX INCREMENT REVENUE
Parcel 9 (Portion) - Northville Lumber Co.
MITC Redevelopment Area
Plymouth Township, Michigan
4/14/2023

Estimated Taxable Value (TV) Increase Rate: 2% per year

Plan Year Calendar Year	6	7	8	9	10	11	12	13	14	15	16	17	18	19	20	21	22	
	2024	2025	2026	2027	2028	2029	2030	2031	2032	2033	2034	2035	2036	2037	2038	2039	2040	
Base Taxable Value	\$ -	\$ -	\$ -	\$ -	\$ -	\$ -	\$ -	\$ -	\$ -	\$ -	\$ -	\$ -	\$ -	\$ -	\$ -	\$ -	\$ -	
Estimated New TV ¹	\$ 1,500,000	\$ 3,750,000	\$ 3,825,000	\$ 3,901,500	\$ 3,979,530	\$ 4,059,121	\$ 4,140,303	\$ 4,223,109	\$ 4,307,571	\$ 4,393,723	\$ 4,481,597	\$ 4,571,229	\$ 4,662,654	\$ 4,755,907	\$ 4,851,025	\$ 4,948,045	\$ 5,047,006	
Incremental Difference (New TV - Base TV)	\$ 1,500,000	\$ 3,750,000	\$ 3,825,000	\$ 3,901,500	\$ 3,979,530	\$ 4,059,121	\$ 4,140,303	\$ 4,223,109	\$ 4,307,571	\$ 4,393,723	\$ 4,481,597	\$ 4,571,229	\$ 4,662,654	\$ 4,755,907	\$ 4,851,025	\$ 4,948,045	\$ 5,047,006	
School Capture																		
	Millage Rate																	
State Education Tax (SET)	6.0000	\$ 4,500	\$ 11,250	\$ 11,475	\$ 11,705	\$ 11,939	\$ 24,355	\$ 24,842	\$ 25,339	\$ 25,845	\$ 26,362	\$ 26,890	\$ 27,427	\$ 27,976	\$ 28,535	\$ 29,106	\$ 29,688	\$ 30,282
School Operating	18.0000	\$ 13,500	\$ 33,750	\$ 34,425	\$ 35,114	\$ 35,816	\$ 73,064	\$ 74,525	\$ 76,016	\$ 77,536	\$ 79,087	\$ 80,669	\$ 82,282	\$ 83,928	\$ 85,606	\$ 87,318	\$ 89,065	\$ 90,846
School Total	24.0000	\$ 18,000	\$ 45,000	\$ 45,900	\$ 46,819	\$ 47,755	\$ 97,419	\$ 99,367	\$ 101,355	\$ 103,381	\$ 105,449	\$ 107,559	\$ 109,709	\$ 111,904	\$ 114,141	\$ 116,424	\$ 118,753	\$ 121,128
Local Capture																		
	Millage Rate																	
Northville Township Operating	0.7686	\$ 576	\$ 1,441	\$ 1,470	\$ 1,499	\$ 1,529	\$ 3,120	\$ 3,182	\$ 3,246	\$ 3,311	\$ 3,377	\$ 3,445	\$ 3,513	\$ 3,584	\$ 3,655	\$ 3,728	\$ 3,803	\$ 3,879
Public Safety	6.4366	\$ 4,827	\$ 12,069	\$ 12,310	\$ 12,556	\$ 12,807	\$ 26,127	\$ 26,649	\$ 27,182	\$ 27,726	\$ 28,281	\$ 28,846	\$ 29,423	\$ 30,012	\$ 30,612	\$ 31,224	\$ 31,849	\$ 32,486
Shared Services	0.7561	\$ 567	\$ 1,418	\$ 1,446	\$ 1,475	\$ 1,504	\$ 3,069	\$ 3,130	\$ 3,193	\$ 3,257	\$ 3,322	\$ 3,389	\$ 3,456	\$ 3,525	\$ 3,596	\$ 3,668	\$ 3,741	\$ 3,816
School Sinking Fund	0.4698	\$ 352	\$ 881	\$ 898	\$ 916	\$ 935	\$ 1,907	\$ 1,945	\$ 1,984	\$ 2,024	\$ 2,064	\$ 2,105	\$ 2,148	\$ 2,191	\$ 2,234	\$ 2,279	\$ 2,325	\$ 2,371
RESA Operating	0.0956	\$ 72	\$ 179	\$ 183	\$ 186	\$ 190	\$ 388	\$ 396	\$ 404	\$ 412	\$ 420	\$ 428	\$ 437	\$ 446	\$ 455	\$ 464	\$ 473	\$ 482
RESA Special Ed.	3.3443	\$ 2,508	\$ 6,271	\$ 6,396	\$ 6,524	\$ 6,654	\$ 13,575	\$ 13,846	\$ 14,123	\$ 14,406	\$ 14,694	\$ 14,988	\$ 15,288	\$ 15,593	\$ 15,905	\$ 16,223	\$ 16,548	\$ 16,879
RESA Enhancement	1.9876	\$ 1,491	\$ 3,727	\$ 3,801	\$ 3,877	\$ 3,955	\$ 8,068	\$ 8,229	\$ 8,394	\$ 8,562	\$ 8,733	\$ 8,908	\$ 9,086	\$ 9,267	\$ 9,453	\$ 9,642	\$ 9,835	\$ 10,031
HCMA	0.2070	\$ 155	\$ 388	\$ 396	\$ 404	\$ 412	\$ 840	\$ 857	\$ 874	\$ 892	\$ 910	\$ 928	\$ 946	\$ 965	\$ 984	\$ 1,004	\$ 1,024	\$ 1,045
Library Operating	1.0975	\$ 823	\$ 2,058	\$ 2,099	\$ 2,141	\$ 2,184	\$ 4,455	\$ 4,544	\$ 4,635	\$ 4,728	\$ 4,822	\$ 4,919	\$ 5,017	\$ 5,117	\$ 5,220	\$ 5,324	\$ 5,430	\$ 5,539
Wayne County Operating	6.5928	\$ 4,945	\$ 12,362	\$ 12,609	\$ 12,861	\$ 13,118	\$ 26,761	\$ 27,296	\$ 27,842	\$ 28,399	\$ 28,967	\$ 29,546	\$ 30,137	\$ 30,740	\$ 31,355	\$ 31,982	\$ 32,621	\$ 33,274
WC Jail	0.9358	\$ 702	\$ 1,755	\$ 1,790	\$ 1,826	\$ 1,862	\$ 3,799	\$ 3,874	\$ 3,952	\$ 4,031	\$ 4,112	\$ 4,194	\$ 4,278	\$ 4,363	\$ 4,451	\$ 4,540	\$ 4,630	\$ 4,723
WC Parks	0.2442	\$ 183	\$ 458	\$ 467	\$ 476	\$ 486	\$ 991	\$ 1,011	\$ 1,031	\$ 1,052	\$ 1,073	\$ 1,094	\$ 1,116	\$ 1,139	\$ 1,161	\$ 1,185	\$ 1,208	\$ 1,232
Schoolcraft Community College	2.2700	\$ 1,703	\$ 4,256	\$ 4,341	\$ 4,428	\$ 4,517	\$ 9,214	\$ 9,398	\$ 9,586	\$ 9,778	\$ 9,974	\$ 10,173	\$ 10,377	\$ 10,584	\$ 10,796	\$ 11,012	\$ 11,232	\$ 11,457
Local Total	25.2059	\$ 18,904	\$ 47,263	\$ 48,206	\$ 49,169	\$ 50,153	\$ 102,314	\$ 104,357	\$ 106,446	\$ 108,578	\$ 110,749	\$ 112,963	\$ 115,222	\$ 117,526	\$ 119,877	\$ 122,275	\$ 124,719	\$ 127,214
Non-Capturable Millages																		
	Millage Rate																	
WC Zoo	0.0992	\$ 74	\$ 186	\$ 190	\$ 194	\$ 197	\$ 403	\$ 411	\$ 419	\$ 427	\$ 436	\$ 445	\$ 453	\$ 463	\$ 472	\$ 481	\$ 491	\$ 501
WC Art Institute	0.1986	\$ 149	\$ 372	\$ 380	\$ 387	\$ 395	\$ 806	\$ 822	\$ 839	\$ 855	\$ 873	\$ 890	\$ 908	\$ 926	\$ 945	\$ 963	\$ 983	\$ 1,002
Property Bond Prop	0.3500	\$ 263	\$ 656	\$ 669	\$ 683	\$ 696	\$ 1,421	\$ 1,449	\$ 1,478	\$ 1,508	\$ 1,538	\$ 1,569	\$ 1,600	\$ 1,632	\$ 1,665	\$ 1,698	\$ 1,732	\$ 1,766
School Debt	1.7000	\$ 1,275	\$ 3,188	\$ 3,251	\$ 3,316	\$ 3,383	\$ 6,901	\$ 7,039	\$ 7,179	\$ 7,323	\$ 7,469	\$ 7,619	\$ 7,771	\$ 7,927	\$ 8,085	\$ 8,247	\$ 8,412	\$ 8,580
Total Non-Capturable Taxes	2.3478	\$ 1,761	\$ 4,402	\$ 4,490	\$ 4,580	\$ 4,672	\$ 9,530	\$ 9,721	\$ 9,915	\$ 10,113	\$ 10,316	\$ 10,522	\$ 10,732	\$ 10,947	\$ 11,166	\$ 11,389	\$ 11,617	\$ 11,849
Total Tax Increment Revenue (TIR) Available for Capture		\$ 36,904	\$ 92,263	\$ 94,106	\$ 95,988	\$ 97,908	\$ 199,733	\$ 203,724	\$ 207,801	\$ 211,959	\$ 216,198	\$ 220,522	\$ 224,931	\$ 229,430	\$ 234,018	\$ 238,699	\$ 243,472	\$ 248,342

Footnotes:
 1. The taxable value at project completion was based on input from Northville Township
 Grey shading shows years where 50% of tax revenues are allocated to the State Land Bank (5/50 Tax).



Table 2-3
TAX INCREMENT REVENUE
Parcel 9 (Portion) - Northville Lumber Co.
MITC Redevelopment Area
Plymouth Township, Michigan
4/14/2023

Estimated Taxable Value (TV) Increase Rate:

Plan Year	23	24	25	26	27	28	29	30	31	32	33	TOTAL	
	2041	2042	2043	2044	2045	2046	2047	2048	2049	2050	2051		
Base Taxable Value	\$ -	\$ -	\$ -	\$ -	\$ -	\$ -	\$ -	\$ -	\$ -	\$ -	\$ -		
Estimated New TV ¹	\$ 5,147,946	\$ 5,250,905	\$ 5,355,923	\$ 5,463,042	\$ 5,572,303	\$ 5,683,749	\$ 5,797,424	\$ 5,913,372	\$ 6,031,640	\$ 6,152,272	\$ 6,275,318		
Incremental Difference (New TV - Base TV)	\$ 5,147,946	\$ 5,250,905	\$ 5,355,923	\$ 5,463,042	\$ 5,572,303	\$ 5,683,749	\$ 5,797,424	\$ 5,913,372	\$ 6,031,640	\$ 6,152,272	\$ 6,275,318		
School Capture													
	Millage Rate												
State Education Tax (SET)	6.0000	\$ 30,888	\$ 31,505	\$ 32,136	\$ 32,778	\$ 33,434	\$ 34,102	\$ 34,785	\$ 35,480	\$ 36,190	\$ 36,914	\$ 37,652	\$ 753,380
School Operating	18.0000	\$ 92,663	\$ 94,516	\$ 96,407	\$ 98,335	\$ 100,301	\$ 102,307	\$ 104,354	\$ 106,441	\$ 108,570	\$ 110,741	\$ 112,956	\$ 2,260,138
School Total	24.0000	\$ 123,551	\$ 126,021	\$ 128,543	\$ 131,113	\$ 133,735	\$ 136,409	\$ 139,139	\$ 141,921	\$ 144,760	\$ 147,655	\$ 150,608	\$ 3,013,518
Local Capture													
	Millage Rate												
Northville Township Operating	0.7686	\$ 3,957	\$ 4,036	\$ 4,117	\$ 4,199	\$ 4,283	\$ 4,369	\$ 4,456	\$ 4,545	\$ 4,636	\$ 4,729	\$ 4,823	\$ 96,508
Public Safety	6.4366	\$ 33,135	\$ 33,798	\$ 34,474	\$ 35,163	\$ 35,867	\$ 36,584	\$ 37,316	\$ 38,062	\$ 38,823	\$ 39,600	\$ 40,392	\$ 808,200
Shared Services	0.7561	\$ 3,892	\$ 3,970	\$ 4,050	\$ 4,131	\$ 4,213	\$ 4,297	\$ 4,383	\$ 4,471	\$ 4,561	\$ 4,652	\$ 4,745	\$ 94,937
School Sinking Fund	0.4698	\$ 2,419	\$ 2,467	\$ 2,516	\$ 2,567	\$ 2,618	\$ 2,670	\$ 2,724	\$ 2,778	\$ 2,834	\$ 2,890	\$ 2,948	\$ 58,990
RESA Operating	0.0956	\$ 492	\$ 502	\$ 512	\$ 522	\$ 533	\$ 543	\$ 554	\$ 565	\$ 577	\$ 588	\$ 600	\$ 12,003
RESA Special Ed.	3.3443	\$ 17,216	\$ 17,561	\$ 17,912	\$ 18,270	\$ 18,635	\$ 19,008	\$ 19,388	\$ 19,776	\$ 20,172	\$ 20,575	\$ 20,987	\$ 419,921
RESA Enhancement	1.9876	\$ 10,232	\$ 10,437	\$ 10,645	\$ 10,858	\$ 11,076	\$ 11,297	\$ 11,523	\$ 11,753	\$ 11,988	\$ 12,228	\$ 12,473	\$ 249,569
HCMA	0.2070	\$ 1,066	\$ 1,087	\$ 1,109	\$ 1,131	\$ 1,153	\$ 1,177	\$ 1,200	\$ 1,224	\$ 1,249	\$ 1,274	\$ 1,299	\$ 25,993
Library Operating	1.0975	\$ 5,650	\$ 5,763	\$ 5,878	\$ 5,996	\$ 6,116	\$ 6,238	\$ 6,363	\$ 6,490	\$ 6,620	\$ 6,752	\$ 6,887	\$ 137,808
Wayne County Operating	6.5928	\$ 33,939	\$ 34,618	\$ 35,311	\$ 36,017	\$ 36,737	\$ 37,472	\$ 38,221	\$ 38,986	\$ 39,765	\$ 40,561	\$ 41,372	\$ 827,814
WC Jail	0.9358	\$ 4,817	\$ 4,914	\$ 5,012	\$ 5,112	\$ 5,215	\$ 5,319	\$ 5,425	\$ 5,534	\$ 5,644	\$ 5,757	\$ 5,872	\$ 117,503
WC Parks	0.2442	\$ 1,257	\$ 1,282	\$ 1,308	\$ 1,334	\$ 1,361	\$ 1,388	\$ 1,416	\$ 1,444	\$ 1,473	\$ 1,502	\$ 1,532	\$ 30,660
Schoolcraft Community College	2.2700	\$ 11,686	\$ 11,920	\$ 12,158	\$ 12,401	\$ 12,649	\$ 12,902	\$ 13,160	\$ 13,423	\$ 13,692	\$ 13,966	\$ 14,245	\$ 285,028
Local Total	25.2059	\$ 129,758	\$ 132,355	\$ 135,002	\$ 137,701	\$ 140,456	\$ 143,264	\$ 146,129	\$ 149,051	\$ 152,034	\$ 155,074	\$ 158,175	\$ 3,164,934
Non-Capturable Millages													
	Millage Rate												
WC Zoo	0.0992	\$ 511	\$ 521	\$ 531	\$ 542	\$ 553	\$ 564	\$ 575	\$ 587	\$ 598	\$ 610	\$ 623	\$ 12,458
WC Art Institute	0.1986	\$ 1,022	\$ 1,043	\$ 1,064	\$ 1,085	\$ 1,107	\$ 1,129	\$ 1,151	\$ 1,174	\$ 1,198	\$ 1,222	\$ 1,246	\$ 24,936
Property Bond Prop	0.3500	\$ 1,802	\$ 1,838	\$ 1,875	\$ 1,912	\$ 1,950	\$ 1,989	\$ 2,029	\$ 2,070	\$ 2,111	\$ 2,153	\$ 2,196	
School Debt	1.7000	\$ 8,752	\$ 8,927	\$ 9,105	\$ 9,287	\$ 9,473	\$ 9,662	\$ 9,856	\$ 10,053	\$ 10,254	\$ 10,459	\$ 10,668	\$ 213,461
Total Non-Capturable Taxes	2.3478	\$ 12,086	\$ 12,328	\$ 12,575	\$ 12,826	\$ 13,083	\$ 13,344	\$ 13,611	\$ 13,883	\$ 14,161	\$ 14,444	\$ 14,733	\$ 294,796
Total Tax Increment Revenue (TIR) Available for Capture		\$ 253,309	\$ 258,376	\$ 263,545	\$ 268,814	\$ 274,191	\$ 279,673	\$ 285,268	\$ 290,972	\$ 296,794	\$ 302,729	\$ 308,783	\$ 6,178,452

APPENDIX C

TABLE 3 TIR REIMBURSEMENT ALLOCATION (PARCEL 13, PARCEL 11/12, PARCEL 9 (NORTHVILLE LUMBER CO. PORTION), MITC INFRASTRUCTURE)



**TABLE 3
ELIGIBLE COSTS REIMBURSEMENT SUMMARY
Parcel 13, Parcel 11/12, and MITC Infrastructure
MITC Redevelopment Area
Plymouth Township, Michigan
4/26/2023**

Developer Maximum Reimbursement	PARCEL 13		PARCELS 11/12		PARCEL 9 (Northville Lumber Co. Portion)		MITC INFRASTRUCTURE		Total
	Proportionality	Incremental Taxes	Proportionality	Incremental Taxes	Proportionality	Incremental Taxes	Proportionality	Incremental Taxes	
State	48.3%	\$ 750,424	0.0%	\$ -	48.8%	\$ 1,673,596	52.3%	\$ 16,138,905	\$ 16,889,329
Local	51.7%	\$ 720,347	100.0%	\$ 1,356,494	51.2%	\$ 1,771,410	47.7%	\$ 14,736,636	\$ 16,813,477
TOTAL		\$ 1,470,771		\$ 1,356,494				\$ 30,875,534	\$ 33,702,799
EGLE	24.1%	\$ 354,061	100.0%	\$ 1,356,494	53.9%	\$ 1,946,837	3.5%	\$ 1,010,000	\$ 2,720,555
MSF	75.9%	\$ 1,116,709	0.0%	\$ -	46.1%	\$ 1,663,284	96.5%	\$ 29,865,534	\$ 30,982,243

Estimated Total Years of Plan	30	Estimated Capture	
		Administrative Fees	\$ 2,378,407
		State Revolving Fund	\$ 3,467,424
		LBRF	\$ -

Plan/Capture Year	3	4	5	6	7	8	9	10	11	12	13	14	15	16	17	18	19	20	21	
Calendar Year	2021	2022	2023	2024	2025	2026	2027	2028	2029	2030	2031	2032	2033	2034	2035	2036	2037	2038	2039	
Total State Incremental Revenue	\$ 72,000	\$ 252,000	\$ 232,160	\$ 339,687	\$ 422,080	\$ 442,403	\$ 480,771	\$ 490,386	\$ 923,447	\$ 941,915	\$ 960,754	\$ 979,969	\$ 999,569	\$ 1,019,560	\$ 1,039,951	\$ 1,060,751	\$ 1,081,964	\$ 1,103,604	\$ 1,125,677	
State Brownfield Redevelopment Fund (50% of SET)	\$ 9,000	\$ 31,500	\$ 29,020	\$ 44,711	\$ 58,385	\$ 61,038	\$ 65,949	\$ 67,268	\$ 127,609	\$ 130,161	\$ 132,764	\$ 135,419	\$ 138,128	\$ 140,891	\$ 143,708	\$ 146,583	\$ 149,514	\$ 152,504	\$ 155,554	
State TIR Available for Reimbursement	\$ 63,000	\$ 220,500	\$ 203,140	\$ 294,976	\$ 363,695	\$ 381,365	\$ 414,822	\$ 423,118	\$ 795,838	\$ 811,754	\$ 827,990	\$ 844,550	\$ 861,441	\$ 878,669	\$ 896,243	\$ 914,168	\$ 932,450	\$ 951,100	\$ 970,123	
Total Local Incremental Revenue	\$ 67,175	\$ 235,112	\$ 216,609	\$ 319,051	\$ 399,088	\$ 418,155	\$ 454,063	\$ 463,139	\$ 873,004	\$ 890,461	\$ 908,271	\$ 926,436	\$ 944,966	\$ 963,863	\$ 983,144	\$ 1,002,805	\$ 1,022,861	\$ 1,043,318	\$ 1,064,186	
BRA Administrative Fee (10%)	\$ 6,718	\$ 23,511	\$ 21,661	\$ 31,905	\$ 39,909	\$ 41,816	\$ 45,406	\$ 46,314	\$ 87,300	\$ 89,046	\$ 90,827	\$ 92,644	\$ 94,497	\$ 96,386	\$ 98,314	\$ 100,281	\$ 102,286	\$ 104,332	\$ 106,419	
Local TIR Available for Reimbursement	\$ 60,457	\$ 211,601	\$ 194,948	\$ 287,146	\$ 359,179	\$ 376,339	\$ 408,657	\$ 416,825	\$ 785,704	\$ 801,415	\$ 817,444	\$ 833,792	\$ 850,469	\$ 867,477	\$ 884,830	\$ 902,524	\$ 920,575	\$ 938,986	\$ 957,767	
Total State & Local TIR Available	\$ 60,457	\$ 211,601	\$ 398,088	\$ 582,122	\$ 722,874	\$ 757,704	\$ 823,479	\$ 839,943	\$ 1,581,542	\$ 1,613,169	\$ 1,645,434	\$ 1,678,342	\$ 1,711,910	\$ 1,746,146	\$ 1,781,073	\$ 1,816,692	\$ 1,853,025	\$ 1,890,086	\$ 1,927,890	
Total TIR Available to Developers	\$ 42,320	\$ 148,121	\$ 157,387	\$ 254,711	\$ 322,524	\$ 335,961	\$ 360,032	\$ 367,230	\$ 320,309	\$ 220,818	\$ 225,236	\$ 229,740	\$ 234,334	\$ 239,022	\$ 243,803	\$ 248,679	\$ 253,651	\$ 241,795	\$ 151,309	
Total TIR Available to MITC Infrastructure	\$ 18,137	\$ 63,480	\$ 240,701	\$ 327,411	\$ 400,350	\$ 421,743	\$ 463,447	\$ 472,713	\$ 1,261,233	\$ 1,392,351	\$ 1,420,198	\$ 1,448,602	\$ 1,477,576	\$ 1,507,124	\$ 1,537,270	\$ 1,568,013	\$ 1,599,374	\$ 1,648,291	\$ 1,776,581	
REIMBURSEMENT BALANCES	Beginning Balances																			
PARCEL 13 Reimbursement Balance	\$ 1,470,770		\$ 1,429,762	\$ 1,346,107	\$ 1,260,780	\$ 1,173,743	\$ 1,084,967	\$ 994,415	\$ 902,053	\$ 807,842	\$ 711,747	\$ 613,732	\$ 513,757	\$ 411,781	\$ 307,765	\$ 201,669	\$ 93,452	\$ -	\$ -	
PARCEL 11/12 Reimbursement Balance	\$ 1,356,494	\$ 1,314,174	\$ 1,166,053	\$ 1,049,674	\$ 901,553	\$ 721,694	\$ 531,254	\$ 319,651	\$ 103,820											
PARCEL 9 (NL, LLC) Reimbursement Balance	\$ 3,610,121		\$ 3,587,186	\$ 3,529,848	\$ 3,471,364	\$ 3,411,711	\$ 3,350,864	\$ 3,226,737	\$ 3,100,130	\$ 2,970,989	\$ 2,839,264	\$ 2,704,905	\$ 2,567,859	\$ 2,428,072	\$ 2,285,489	\$ 2,140,055	\$ 1,991,712	\$ 1,840,403		
MITC INFRASTRUCTURE Reimbursement Balance	\$ 30,875,534	\$ 30,856,762	\$ 30,791,060	\$ 30,550,358	\$ 30,222,947	\$ 29,822,597	\$ 29,400,853	\$ 28,937,406	\$ 28,464,692	\$ 27,203,460	\$ 25,811,110	\$ 24,390,912	\$ 22,942,310	\$ 21,464,735	\$ 19,957,612	\$ 18,420,342	\$ 16,852,329	\$ 15,252,955	\$ 13,604,665	\$ 11,828,085
PARCEL 13																				
MSF Non-Environmental Costs	\$ 1,116,709		\$ 31,125	\$ 63,494	\$ 64,763	\$ 66,061	\$ 67,381	\$ 68,729	\$ 70,103	\$ 71,506	\$ 72,936	\$ 74,393	\$ 75,881	\$ 77,400	\$ 78,948	\$ 80,527	\$ 82,137	\$ 83,775	\$ 85,442	
State Tax Reimbursement	\$ 569,773		\$ 15,881	\$ 32,397	\$ 33,044	\$ 33,706	\$ 34,379	\$ 35,067	\$ 35,768	\$ 36,484	\$ 37,213	\$ 37,958	\$ 38,717	\$ 39,491	\$ 40,281	\$ 41,087	\$ 41,908	\$ 42,745	\$ 43,600	
Local Tax Reimbursement	\$ 546,937		\$ 15,244	\$ 31,098	\$ 31,719	\$ 32,355	\$ 33,002	\$ 33,662	\$ 34,335	\$ 35,023	\$ 35,723	\$ 36,436	\$ 37,164	\$ 37,908	\$ 38,667	\$ 39,440	\$ 40,228	\$ 41,032	\$ 41,852	
Total MSF Reimbursement Balance			\$ 1,085,584	\$ 1,022,090	\$ 957,327	\$ 891,266	\$ 823,885	\$ 755,156	\$ 685,053	\$ 613,547	\$ 540,611	\$ 466,218	\$ 390,337	\$ 312,937	\$ 233,989	\$ 153,462	\$ 71,325	\$ -	\$ -	
EGLE Environmental Costs	\$ 354,061		\$ 9,883	\$ 20,161	\$ 20,564	\$ 20,976	\$ 21,395	\$ 21,823	\$ 22,259	\$ 22,705	\$ 23,159	\$ 23,622	\$ 24,094	\$ 24,576	\$ 25,068	\$ 25,569	\$ 26,080	\$ 26,600	\$ 27,130	
State Tax Reimbursement	\$ 180,651		\$ 5,042	\$ 10,287	\$ 10,492	\$ 10,702	\$ 10,916	\$ 11,135	\$ 11,357	\$ 11,584	\$ 11,816	\$ 12,052	\$ 12,294	\$ 12,539	\$ 12,790	\$ 13,046	\$ 13,307	\$ 13,574	\$ 13,847	
Local Tax Reimbursement	\$ 173,410		\$ 4,840	\$ 9,874	\$ 10,071	\$ 10,273	\$ 10,479	\$ 10,688	\$ 10,902	\$ 11,120	\$ 11,343	\$ 11,569	\$ 11,801	\$ 12,037	\$ 12,278	\$ 12,523	\$ 12,773	\$ 13,028	\$ 13,293	
Total EGLE Reimbursement Balance			\$ 344,178	\$ 324,017	\$ 303,453	\$ 282,477	\$ 261,082	\$ 239,259	\$ 217,000	\$ 194,295	\$ 171,136	\$ 147,514	\$ 123,420	\$ 98,844	\$ 73,776	\$ 48,207	\$ 22,127	\$ -	\$ -	
Total Annual Parcel 13 Reimbursement	\$ 1,470,770		\$ 41,008	\$ 83,655	\$ 85,327	\$ 87,037	\$ 88,776	\$ 90,552	\$ 92,362	\$ 94,211	\$ 96,095	\$ 98,015	\$ 99,975	\$ 101,976	\$ 104,016	\$ 106,096	\$ 108,217	\$ 93,452	\$ -	
PARCELS 11/12 RIDGE 5 CORPORATE PARK																				
EGLE Environmental Costs	\$ 1,356,494	\$ 42,320	\$ 148,121	\$ 116,379	\$ 148,121	\$ 179,859	\$ 190,440	\$ 211,603	\$ 215,831	\$ 103,820										
State Tax Reimbursement	\$ -	\$ -	\$ -	\$ -	\$ -	\$ -	\$ -	\$ -	\$ -	\$ -										
Local Tax Reimbursement	\$ 1,356,494	\$ 42,320	\$ 148,121	\$ 116,379	\$ 148,121	\$ 179,859	\$ 190,440	\$ 211,603	\$ 215,831	\$ 103,820										
Total EGLE Reimbursement Balance		\$ 1,314,174	\$ 1,166,053	\$ 1,049,674	\$ 901,553	\$ 721,694	\$ 531,254	\$ 319,651	\$ 103,820	\$ -										
Total Annual Parcel 11/12 Reimbursement	\$ 1,356,494	\$ 42,320	\$ 148,121	\$ 116,379	\$ 148,121	\$ 179,859	\$ 190,440	\$ 211,603	\$ 215,831	\$ 103,820										
Parcel 9 Northville Lumber																				
MSF Non-Environmental Costs	\$ 1,663,284			\$ 10,567	\$ 26,417	\$ 26,945	\$ 27,484	\$ 28,034	\$ 28,591	\$ 29,157	\$ 29,732	\$ 30,316	\$ 30,909	\$ 31,511	\$ 32,122	\$ 32,742	\$ 33,371	\$ 34,009	\$ 34,656	
State Tax Reimbursement	\$ 830,984			\$ 5,080	\$ 12,699	\$ 12,953	\$ 13,212	\$ 13,476	\$ 13,745	\$ 14,018	\$ 14,294	\$ 14,573	\$ 14,855	\$ 15,140	\$ 15,429	\$ 15,722	\$ 16,019	\$ 16,320	\$ 16,625	
Local Tax Reimbursement	\$ 783,597			\$ 5,487	\$ 13,718	\$ 13,992	\$ 14,272	\$ 14,557	\$ 14,846	\$ 15,139	\$ 15,436	\$ 15,737	\$ 16,041	\$ 16,348	\$ 16,659	\$ 16,974	\$ 17,292	\$ 17,614	\$ 17,940	
Total MSF Reimbursement Balance				\$ 1,652,717	\$ 1,626,300	\$ 1,599,355	\$ 1,571,871	\$ 1,543,837	\$ 1,486,648	\$ 1,428,317	\$ 1,368,818	\$ 1,308,129	\$ 1,246,226	\$ 1,183,085	\$ 1,118,681	\$ 1,052,989	\$ 985,983	\$ 917,637	\$ 847,925	
EGLE Environmental Costs	\$ 1,946,837			\$ 12,368	\$ 30,921	\$ 31,539	\$ 32,169	\$ 32,813	\$ 33,472	\$ 34,146	\$ 34,835	\$ 35,538	\$ 36,256	\$ 36,989	\$ 37,737	\$ 38,500	\$ 39,278	\$ 40,071	\$ 40,880	
State Tax Reimbursement	\$ 842,611			\$ 5,945	\$ 14,864	\$ 15,161	\$ 15,464	\$ 15,774	\$ 16,090	\$ 16,412	\$ 16,740	\$ 17,073	\$ 17,411	\$ 17,754	\$ 18,102	\$ 18,455	\$ 18,813	\$ 19,176	\$ 19,544	
Local Tax Reimbursement	\$ 987,813			\$ 6,422	\$ 16,057	\$ 16,378	\$ 16,705	\$ 17,039	\$ 17,378	\$ 17,721	\$ 18,069	\$ 18,422	\$ 18,780	\$ 19,143	\$ 19,511	\$ 19,884	\$ 20,262	\$ 20,645	\$ 21,033	
Total EGLE Reimbursement Balance				\$ 1,934,469	\$ 1,903,548	\$ 1,872,009	\$ 1,839,840	\$ 1,807,027	\$ 1,740,089	\$ 1,671,813	\$ 1,602,171	\$ 1,531,135	\$ 1,458,679	\$ 1,384,774	\$ 1,309,391	\$ 1,232,500	\$ 1,154,072	\$ 1,074,075	\$ 992,478	
Total Annual Parcel 9 Reimbursement	\$ 3,610,121	\$ -	\$ -	\$ 22,935	\$ 57,338	\$ 58,484	\$ 59,653	\$ 60,847	\$ 124,127	\$ 126,607	\$ 129,141	\$ 131,725	\$ 134,359	\$ 137,046	\$ 139,787	\$ 142,583	\$ 145,434	\$ 148,343	\$ 151,309	
MITC INFRASTRUCTURE																				
MSF Non-Environmental Costs	\$ 29,865,534	\$ 18,137	\$ 63,480	\$ 232,277	\$ 315,952	\$ 386,338	\$ 406,983	\$ 447,226	\$ 456,169	\$ 1,217,089	\$ 1,343,618	\$ 1,370,491	\$ 1,397,901	\$ 1,425,860	\$ 1,454,374	\$ 1,483,466	\$ 1,513,133	\$ 1,543,396	\$ 1,590,600	
State Tax Reimbursement	\$ 15,609,674			\$ 175,839	\$ 232,823	\$ 282,355	\$ 298,034	\$ 328,920	\$ 335,498	\$ 664,927	\$ 678,225	\$ 691,790	\$ 705,626	\$ 719,738	\$ 734,132	\$ 748,816	\$ 763,792	\$ 779,067	\$ 802,985	
Local Tax Reimbursement	\$ 14,255,862	\$ 18,137	\$ 63,480	\$ 5																



**TABLE 3
ELIGIBLE COSTS REIMBURSEMENT SUMMARY
Parcel 13, Parcel 11/12, and MITC Infrastructure
MITC Redevelopment Area
Plymouth Township, Michigan
4/26/2023**

	22	23	24	25	26	27	28	29	30	TOTAL
	2040	2041	2042	2043	2044	2045	2046	2047	2048	
Total State Incremental Revenue	\$ 1,148,190	\$ 1,171,155	\$ 1,194,575	\$ 1,218,468	\$ 1,242,837	\$ 1,267,693	\$ 1,293,048	\$ 1,318,911	\$ 1,345,288	\$ 25,168,813
State Brownfield Redevelopment Fund (50% of SET)	\$ 158,665	\$ 161,839	\$ 165,074	\$ 168,377	\$ 171,744	\$ 175,179	\$ 178,682	\$ 182,257	\$ 185,901	\$ 3,467,424
State TIR Available for Reimbursement	\$ 989,525	\$ 1,009,316	\$ 1,029,501	\$ 1,050,091	\$ 1,071,093	\$ 1,092,514	\$ 1,114,366	\$ 1,136,654	\$ 1,159,387	\$ 21,701,389
Total Local Incremental Revenue	\$ 1,085,468	\$ 1,107,176	\$ 1,129,322	\$ 1,151,907	\$ 1,174,948	\$ 1,198,446	\$ 1,222,411	\$ 1,246,861	\$ 1,271,799	\$ 23,784,045
BRA Administrative Fee (10%)	\$ 108,547	\$ 110,718	\$ 112,932	\$ 115,191	\$ 117,495	\$ 119,845	\$ 122,241	\$ 124,686	\$ 127,180	\$ 2,378,407
Local TIR Available for Reimbursement	\$ 976,921	\$ 996,458	\$ 1,016,390	\$ 1,036,716	\$ 1,057,453	\$ 1,078,601	\$ 1,100,170	\$ 1,122,175	\$ 1,144,619	\$ 21,405,638
Total State & Local TIR Available	\$ 1,966,446	\$ 2,005,774	\$ 2,045,891	\$ 2,086,807	\$ 2,128,546	\$ 2,171,115	\$ 2,214,536	\$ 2,258,829	\$ 2,304,006	\$ 42,823,527
Total TIR Available to Developers	\$ 154,336	\$ 157,423	\$ 160,572	\$ 163,784	\$ 167,059	\$ 170,400	\$ 198,552	\$ 235,084	\$ 268,080	\$ 6,272,272
Total TIR Available to MITC Infrastructure	\$ 1,812,110	\$ 1,848,351	\$ 1,885,319	\$ 1,923,023	\$ 1,961,487	\$ 2,000,715	\$ 345,747	\$ -	\$ -	\$ 30,821,347
REIMBURSEMENT BALANCES										
PARCEL 13 Reimbursement Balance	\$ -	\$ -	\$ -	\$ -	\$ -	\$ -	\$ -	\$ -	\$ -	\$ -
PARCEL 11/12 Reimbursement Balance	\$ -	\$ -	\$ -	\$ -	\$ -	\$ -	\$ -	\$ -	\$ -	\$ -
PARCEL 9 (NL, LLC) Reimbursement Balance	\$ 1,686,067	\$ 1,528,644	\$ 1,368,072	\$ 1,204,288	\$ 1,037,229	\$ 866,829	\$ 668,277	\$ 433,193	\$ 165,113	\$ -
MITC INFRASTRUCTURE Reimbursement Balance	\$ 10,015,975	\$ 8,167,624	\$ 6,282,305	\$ 4,359,282	\$ 2,397,794	\$ 453,723	\$ -	\$ -	\$ -	\$ -
PARCEL 13										
MSF Non-Environmental Costs	\$ -	\$ -	\$ -	\$ -	\$ -	\$ -	\$ -	\$ -	\$ -	\$ 1,116,709
State Tax Reimbursement										\$ 569,773
Local Tax Reimbursement										\$ 546,937
Total MSF Reimbursement Balance										
EGLE Environmental Costs										\$ 354,061
State Tax Reimbursement										\$ 180,650
Local Tax Reimbursement										\$ 173,411
Total EGLE Reimbursement Balance										
Total Annual Parcel 13 Reimbursement										\$ 1,470,770
PARCELS 11/12 RIDGE 5 CORPORATE										
EGLE Environmental Costs										\$ 1,356,494
State Tax Reimbursement										\$ -
Local Tax Reimbursement										\$ 1,356,494
Total EGLE Reimbursement Balance										
Total Annual Parcel 11/12 Reimbursement										\$ 1,356,494
Parcel 9 Northville Lumber										
MSF Non-Environmental Costs	\$ 71,107	\$ 72,529	\$ 73,980	\$ 75,460	\$ 76,969	\$ 78,508	\$ 87,282	\$ 98,507	\$ 164,882	\$ 1,614,583
State Tax Reimbursement	\$ 34,182	\$ 34,866	\$ 35,563	\$ 36,274	\$ 37,000	\$ 37,739	\$ 45,698	\$ 56,092	\$ 121,619	\$ 830,984
Local Tax Reimbursement	\$ 36,925	\$ 37,663	\$ 38,417	\$ 39,186	\$ 39,969	\$ 40,769	\$ 41,584	\$ 42,415	\$ 43,263	\$ 783,597
Total MSF Reimbursement Balance	\$ 776,818	\$ 704,289	\$ 630,309	\$ 554,849	\$ 477,880	\$ 399,372	\$ 312,090	\$ 213,583	\$ 48,701	
EGLE Environmental Costs	\$ 83,229	\$ 84,894	\$ 86,592	\$ 88,324	\$ 90,090	\$ 91,892	\$ 111,270	\$ 136,577	\$ 103,198	\$ 1,830,425
State Tax Reimbursement	\$ 40,009	\$ 40,809	\$ 41,625	\$ 42,458	\$ 43,307	\$ 44,173	\$ 53,488	\$ 65,654	\$ 12,315	\$ 842,611
Local Tax Reimbursement	\$ 43,220	\$ 44,084	\$ 44,966	\$ 45,866	\$ 46,783	\$ 47,719	\$ 57,781	\$ 70,923	\$ 90,883	\$ 987,813
Total EGLE Reimbursement Balance	\$ 909,249	\$ 824,355	\$ 737,763	\$ 649,439	\$ 559,349	\$ 467,457	\$ 356,187	\$ 219,610	\$ 116,412	
Total Annual Parcel 9 Reimbursement	\$ 154,336	\$ 157,423	\$ 160,572	\$ 163,784	\$ 167,059	\$ 170,400	\$ 198,552	\$ 235,084	\$ 268,080	
MITC INFRASTRUCTURE										
MSF Non-Environmental Costs	\$ 1,748,686	\$ 1,783,659	\$ 1,819,333	\$ 1,855,717	\$ 1,892,836	\$ 1,930,690	\$ 453,723			\$ 29,865,534
State Tax Reimbursement	\$ 883,297	\$ 900,964	\$ 918,982	\$ 937,361	\$ 956,109	\$ 975,230	\$ 229,185			\$ 15,609,674
Local Tax Reimbursement	\$ 865,389	\$ 882,696	\$ 900,351	\$ 918,356	\$ 936,727	\$ 955,460	\$ 224,538			\$ 14,255,862
Total MSF Reimbursement Balance	\$ 9,735,958	\$ 7,952,299	\$ 6,132,966	\$ 4,277,249	\$ 2,384,413	\$ 453,723				
EGLE Environmental Costs	\$ 63,424	\$ 64,692	\$ 65,986	\$ 67,306	\$ 68,652	\$ 13,381				\$ 1,010,000
State Tax Reimbursement	\$ 32,037	\$ 32,677	\$ 33,331	\$ 33,998	\$ 34,678	\$ 6,759				\$ 529,230
Local Tax Reimbursement	\$ 31,387	\$ 32,015	\$ 32,655	\$ 33,308	\$ 33,975	\$ 6,622				\$ 480,773
Total EGLE Reimbursement Balance	\$ 280,017	\$ 215,325	\$ 149,339	\$ 82,033	\$ 13,381	\$ -				
Total Annual MITC Infrastructure Reimbursement	\$ 1,812,110	\$ 1,848,351	\$ 1,885,319	\$ 1,923,023	\$ 1,961,488	\$ 1,944,071	\$ 453,723			\$ 30,875,534

APPENDIX D

LEGAL DESCRIPTIONS AND SURVEYS

PARCEL 9 - NORTHVILLE LUMBER CO. PORTION AND RESIDUAL PORTION



SCALE: 1" = 400'

LEGEND

- SET SET CAPPED IRON OR NAIL & WASHER
- FIB FOUND IRON BAR
- FCI FOUND CAPPED IRON

GRAPHIC SCALE

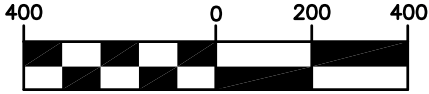

(IN FEET)

1 inch = 400 ft.

LINE TABLE		
LINE	BEARING	LENGTH
L1	S02°31'45"E	325.62'
L2	S87°28'15"W	350.00'
L3	S02°31'45"E	774.19'
L4	S87°28'15"W	27.00'
L5	N02°31'45"W	900.00'
L6	S87°28'15"W	33.00'
L7	S02°31'45"E	1200.00'

CURVE TABLE				
CURVE	LENGTH	RADIUS	DELTA	CHORD
C1(R)	2008.25'	7472.79'		N75°49'57"W 2002.32'
C1(M)	2008.36'	7472.79'	15°23'54"	N75°49'57"W 2002.32'
C2	477.87'	7472.79'	3°39'50"	N85°21'50"W 477.79'

BEARING BASIS:

BEARINGS BASED ON THE MICHIGAN STATE PLANE COORDINATE SYSTEM, SOUTH ZONE (NAD83).

SURVEYOR'S CERTIFICATE

I HEREBY CERTIFY THAT I HAVE SURVEYED AND MAPPED THE LAND ABOVE OR ATTACHED DESCRIBED PARCEL(S) OF LAND ON 9/13/2022, THAT THE ERROR OF CLOSURE IS NO GREATER THAN 1 IN 5000, AND THE SURVEY IS IN FULL COMPLIANCE WITH SECTION NO. 3, ACT 132, P.A. 1970.



SEPTEMBER 12, 2022

PAUL W. KINNUNEN
PROFESSIONAL SURVEYOR NO. 4001048781
EMAIL: PAUL@GREENTECHENGINEERING.NET

NOTES:

1. TITLE WORK NOT PROVIDED. EASEMENTS MAY EXIST AND ARE NOT SHOWN.
2. SEE SHEET 3 FOR EXISTING LEGAL DESCRIPTION.
3. BEARINGS AND DISTANCES NOT DESIGNATED WITH AN (M) FOR MEASURED, AND AN (R) FOR RECORD, ARE CONSIDERED MEASURED AND RECORD VALUES.

WEST 1/4 CORNER SECTION 18
T. 1S.,
R. 8E.,
L. 46822,
P. 1467,
W.C.R.

WAYNE COUNTY

WEST LINE OF SECTION 18 T. 1S., R. 8E.
& CENTERLINE OF ROAD
EAST LINE OF SECTION 13 T. 1S., R. 7E.
SALEM TOWNSHIP



CIVIL ENGINEERS & LAND SURVEYORS

51147 W. Pontiac Trail
Wixom, MI 48393
Phone: (248) 668-0700
Fax: (248) 668-0701

CLIENT:

NORTHVILLE LUMBER

PARCEL SPLIT

PARCEL NO. 77-071-99-0002-701
SECTION: 18 TOWNSHIP: 01S. RANGE: 08E.
NORTHVILLE TOWNSHIP
WAYNE COUNTY
MICHIGAN

DATE: 9-12-2022

DRAWN BY: PWK

CHECKED BY: DJL

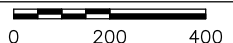

FBK: --

CHF: MM

SCALE HOR 1" = 400 FT.
VER 1" = -- FT.

1 / 3

20-372

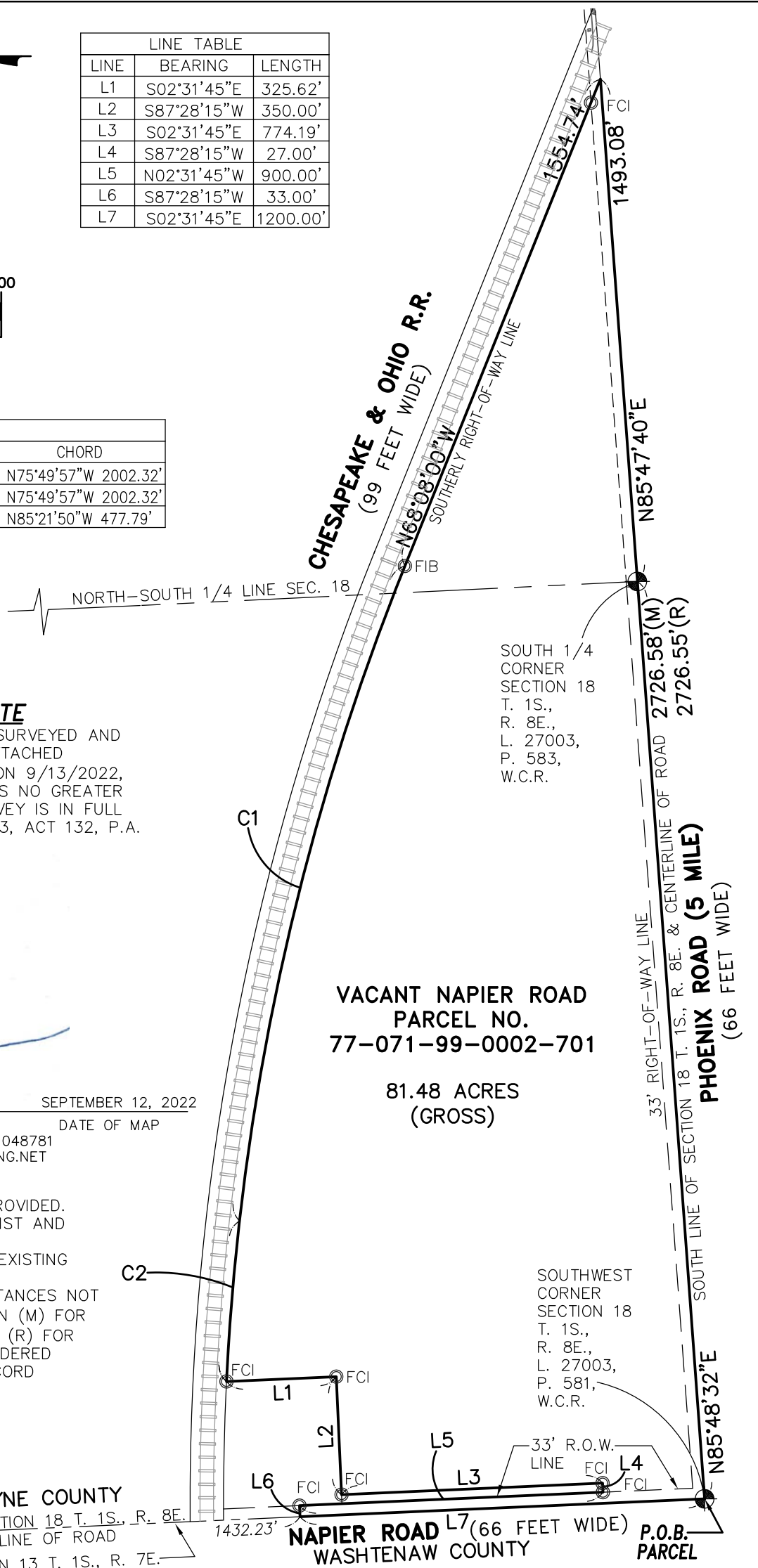

VACANT NAPIER ROAD
PARCEL NO.
77-071-99-0002-701

81.48 ACRES
(GROSS)

NAPIER ROAD L7 (66 FEET WIDE)
WASHTENAW COUNTY

P.O.B.
PARCEL



SCALE: 1" = 400'

LEGEND

- SET SET CAPPED IRON OR NAIL & WASHER
- FIB FOUND IRON BAR
- FCI FOUND CAPPED IRON

GRAPHIC SCALE

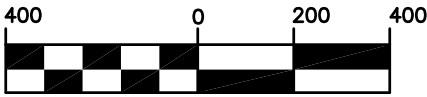

(IN FEET)

1 inch = 400 ft.

LINE TABLE		
LINE	BEARING	LENGTH
L1	N02°31'45"W	1200.00'
L2	N87°28'15"E	33.00'
L3	S02°31'45"E	900.00'
L4	N87°28'15"E	27.00'
L5	N02°31'45"W	774.19'
L6	N87°28'15"E	350.00'
L7	N02°31'45"W	325.62'
L8	S04°11'28"W	1298.39'
L9	S85°48'32"W	1003.03'
L10	N04°11'28"W	1298.39'
L11	S68°08'00"E	1554.74'
L12	S85°47'40"W	1493.08'
L13	S85°48'32"W	1723.55'

CURVE TABLE				
CURVE	LENGTH	RADIUS	DELTA	CHORD
C1	559.85'	7472.79'	04°17'33"	S85°02'58"E 559.72'
C2	1926.38'	7472.79'	14°46'12"	S75°31'06"E 1921.05'

BEARING BASIS:

BEARINGS BASED ON THE MICHIGAN STATE PLANE COORDINATE SYSTEM, SOUTH ZONE (NAD83).

SURVEYOR'S CERTIFICATE

I HEREBY CERTIFY THAT I HAVE SURVEYED AND MAPPED THE LAND ABOVE OR ATTACHED DESCRIBED PARCEL(S) OF LAND ON 9/13/2022, THAT THE ERROR OF CLOSURE IS NO GREATER THAN 1 IN 5000, AND THE SURVEY IS IN FULL COMPLIANCE WITH SECTION NO. 3, ACT 132, P.A. 1970.

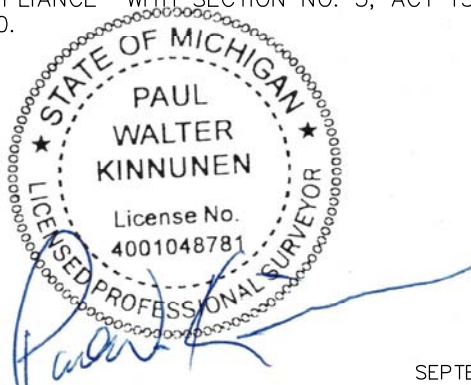

SEPTEMBER 13, 2022

PAUL W. KINNUNEN
PROFESSIONAL SURVEYOR NO. 4001048781
EMAIL: PAUL@GREENTECHENGINEERING.NET

NOTES:

1. TITLE WORK NOT PROVIDED. EASEMENTS MAY EXIST AND ARE NOT SHOWN.
2. SEE SHEET 3 FOR PROPOSED LEGAL DESCRIPTIONS.

WEST 1/4 CORNER SECTION 18 T. 1S., R. 8E., L. 46822, P. 1467, W.C.R.

WAYNE COUNTY

WEST LINE OF SECTION 18 T. 1S., R. 8E. N02°31'45"W & CENTERLINE OF ROAD
EAST LINE OF SECTION 13 T. 1S., R. 7E. SALEM TOWNSHIP



CIVIL ENGINEERS & LAND SURVEYORS

51147 W. Pontiac Trail
Wixom, MI 48393
Phone: (248) 668-0700
Fax: (248) 668-0701

CLIENT:	NORTHVILLE LUMBER		DATE: 9-12-2022
	PARCEL SPLIT		DRAWN BY: PWK
	PARCEL NO. 77-071-99-0002-701		CHECKED BY: DJL
	SECTION: 18 TOWNSHIP: 01S. RANGE: 08E.		0 200 400
	NORTHVILLE TOWNSHIP		FBK: --
	WAYNE COUNTY		2/3
	MICHIGAN		20-372
			SCALE HOR 1" = 400 FT. VER 1" = -- FT.

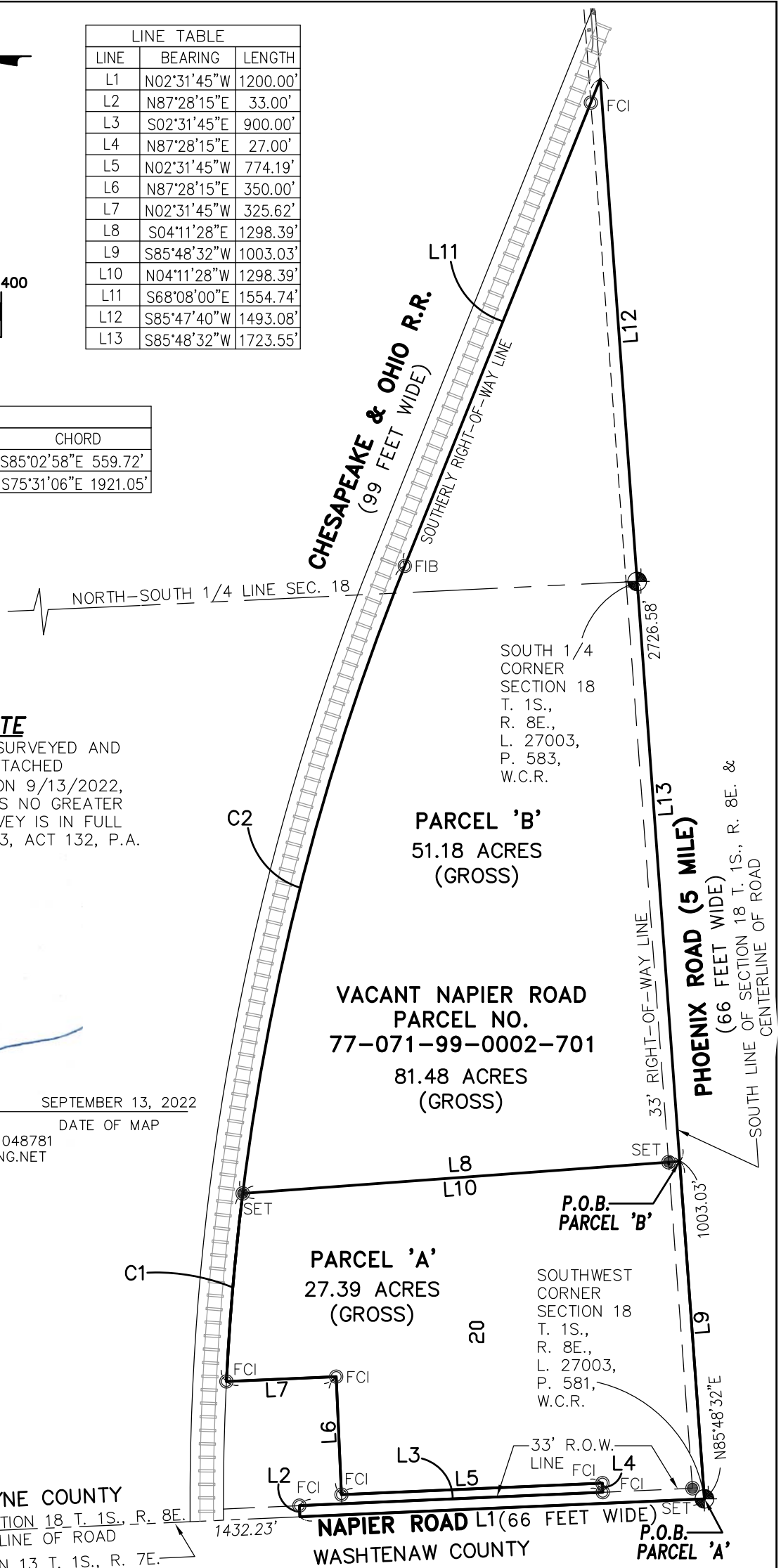

LEGAL DESCRIPTION PARCEL NO. 77-071-99-0002-701 (BY OTHERS):

PART OF THE SOUTH 1/2 OF SECTION 18, T. 1 S., R. 8 E., NORTHVILLE TOWNSHIP, WAYNE COUNTY, MICHIGAN AND BEING MORE PARTICULARLY DESCRIBED AS FOLLOWS:

BEGINNING AT THE SOUTHWEST CORNER OF SECTION 18, T. 1 S., R. 8 E., NORTHVILLE TOWNSHIP, WAYNE COUNTY, MICHIGAN AND PROCEEDING THENCE FROM SAID **POINT OF BEGINNING** NORTH 85 DEGREES 48 MINUTES 32 SECONDS EAST, ALONG THE SOUTH LINE OF SAID SECTION 18, SAID LINE BEING ALSO THE CENTER LINE OF PHOENIX ROAD (66 FEET WIDE), A MEASURED DISTANCE OF 2726.58 FEET (DESCRIBED 2726.55 FEET) TO THE SOUTH 1/4 CORNER OF SAID SECTION 18; THENCE NORTH 85 DEGREES 47 MINUTES 40 SECONDS EAST, CONTINUING ALONG THE SOUTH LINE OF SAID SECTION 18 AND THE CENTER LINE OF SAID PHOENIX ROAD, A DISTANCE OF 1493.08 FEET TO THE POINT OF INTERSECTION OF SAID SECTION LINE, WITH THE SOUTHERLY LINE OF THE CHESAPEAKE AND OHIO RAILROAD RIGHT-OF-WAY (99 FEET WIDE); THENCE NORTH 68 DEGREES 08 MINUTES 00 SECONDS WEST, ALONG SAID SOUTHERLY RAILROAD RIGHT-OF-WAY LINE, A DISTANCE OF 1554.74 FEET TO A POINT OF CURVE IN SAID RIGHT-OF-WAY LINE; THENCE CONTINUING ALONG SAID RAILROAD RIGHT-OF-WAY LINE, ALONG THE ARC OF A CURVE, CONCAVE TO THE SOUTH, RADIUS 7472.79 FEET, AN ARC DISTANCE OF 2008.25 FEET, (CHORD BEARS NORTH 75 DEGREES 49 MINUTES 57 SECONDS WEST, 2002.32 FEET) TO A POINT; THENCE CONTINUING ALONG SAID SOUTHERLY RAILROAD RIGHT-OF-WAY LINE, ALONG THE ARC OF A CURVE, CONCAVE TO THE SOUTH, RADIUS 7472.79 FEET, AN ARC DISTANCE OF 477.87 FEET, (CHORD BEARS NORTH 85 DEGREES 21 MINUTES 50 SECONDS WEST, 477.79 FEET) TO A POINT; THENCE SOUTH 02 DEGREES 31 MINUTES 45 SECONDS EAST, A DISTANCE OF 325.62 FEET TO A POINT; THENCE SOUTH 87 DEGREES 28 MINUTES 15 SECONDS WEST, A DISTANCE OF 350.00 FEET TO A POINT; THENCE SOUTH 02 DEGREES 31 MINUTES 45 SECONDS EAST, ALONG A LINE 60.00 FEET EAST OF, AS MEASURED AT RIGHT ANGLES TO AND PARALLEL WITH THE WEST LINE OF SAID SECTION 18, A DISTANCE OF 774.19 FEET TO A POINT; THENCE SOUTH 87 DEGREES 28 MINUTES 15 SECONDS WEST, A DISTANCE OF 27.00 FEET TO A POINT; THENCE NORTH 02 DEGREES 31 MINUTES 45 SECONDS WEST, ALONG A LINE 33.00 FEET EAST OF, AS MEASURED AT RIGHT ANGLES TO AND PARALLEL WITH THE WEST LINE OF SAID SECTION 18, A DISTANCE OF 900.00 FEET TO A POINT; THENCE SOUTH 87 DEGREES 28 MINUTES 15 SECONDS WEST, A DISTANCE OF 33.00 FEET TO A POINT ON THE WEST LINE OF SAID SECTION 18; THENCE SOUTH 02 DEGREES 31 MINUTES 45 SECONDS EAST, ALONG THE WEST LINE OF SAID SECTION 18, SAID LINE BEING ALSO THE CENTER LINE OF NAPIER ROAD (66 FEET WIDE), A DISTANCE 1200.00 FEET TO THE POINT OF BEGINNING. THE ABOVE DESCRIBED PARCEL IS SUBJECT TO THE RIGHTS OF THE PUBLIC OVER THE SOUTHERLY AND WESTERLY 33 FEET THEREOF FOR ROAD PURPOSES (PHOENIX ROAD AND NAPIER ROAD) .

LEGAL DESCRIPTION PARCEL 'A'):

PART OF THE SOUTHWEST 1/4 OF SECTION 18, T.1S., R.8E., NORTHVILLE TOWNSHIP, WAYNE COUNTY, MICHIGAN, DESCRIBED AS:

BEGINNING AT THE SOUTHWEST CORNER OF SAID SECTION 18; THENCE N02°31'45"W 1200.00 FEET; ALONG THE WEST LINE OF SAID SECTION, SAID LINE ALSO BEING THE CENTERLINE OF NAPIER ROAD, 66 FEET WIDE; THENCE N87°28'15"E 33.00 FEET; THENCE S02°31'45"E 900.00 FEET; THENCE N87°28'15"E 27.00 FEET; THENCE N02°31'45"W 774.19 FEET; THENCE N87°28'15"E 350.00 FEET; THENCE N02°31'45"W 325.62 FEET TO THE SOUTHERLY LINE OF THE CHESAPEAKE AND OHIO RAILROAD RIGHT-OF-WAY, 99 FEET WIDE; THENCE ALONG SAID SOUTHERLY RIGHT-OF-WAY LINE, 559.85 FEET ALONG A CURVE TO THE RIGHT, SAID CURVE HAVING A RADIUS OF 7472.79 FEET, A DELTA ANGLE OF 04°17'33", AND A CHORD BEARING S85°02'58"E 559.72 FEET; THENCE S04°11'28"E 1298.39 FEET TO THE SOUTH LINE OF SAID SECTION 18, SAID SOUTH LINE ALSO BEING THE CENTERLINE OF PHOENIX ROAD (5 MILE), 66 FEET WIDE; THENCE ALONG SAID SOUTH LINE, S85°48'32"W 1003.03 FEET TO SAID SOUTHWEST CORNER OF SAID SECTION 18 AND TO THE **POINT OF BEGINNING**. CONTAINING 27.39 ACRES, AND SUBJECT TO RIGHTS-OF-WAY OVER NAPIER & PHOENIX ROADS, AND SUBJECT TO ANY EASEMENTS AND RESTRICTIONS OF RECORD.

LEGAL DESCRIPTION PARCEL 'B'):

PART OF THE SOUTH 1/2 OF SECTION 18, T.1S., R.8E., NORTHVILLE TOWNSHIP, WAYNE COUNTY, MICHIGAN, DESCRIBED AS:

BEGINNING AT A POINT ON THE SOUTH LINE OF SAID SECTION 18, SAID LINE ALSO BEING THE CENTERLINE OF PHOENIX ROAD (5 MILE), 66 FEET WIDE, BEING DISTANT N85°48'32"E 1003.03 FEET ALONG SAID SOUTH LINE FROM THE SOUTHWEST CORNER OF SAID SECTION 18; THENCE N04°11'28"W 1298.39 FEET TO THE SOUTHERLY LINE OF THE CHESAPEAKE AND OHIO RAILROAD RIGHT-OF-WAY, 99 FEET WIDE; THENCE ALONG SAID SOUTHERLY RIGHT-OF-WAY LINE THE FOLLOWING (2) COURSES, (1) 1926.38 FEET ALONG A CURVE TO THE RIGHT, SAID CURVE HAVING A RADIUS OF 7472.79 FEET, A DELTA ANGLE OF 14°46'12", AND A CHORD BEARING S75°31'06"E 1921.05 FEET, AND (2) S68°08'00"E 1554.74 FEET TO THE SAID SOUTH LINE OF SAID SECTION 18; THENCE ALONG SAID SOUTH LINE, S85°47'40"W 1493.08 FEET TO THE SOUTH 1/4 CORNER OF SAID SECTION 18; THENCE CONTINUING ON SAID SOUTH LINE OF SAID SECTION 18, S85°48'32"W 1723.55 FEET TO THE **POINT OF BEGINNING**. CONTAINING 54.18 ACRES, AND SUBJECT TO RIGHTS-OF-WAY OVER NAPIER & PHOENIX ROADS, AND SUBJECT TO ANY EASEMENTS AND RESTRICTIONS OF RECORD.

SURVEYOR'S CERTIFICATE

I HEREBY CERTIFY THAT I HAVE SURVEYED AND MAPPED THE LAND ABOVE OR ATTACHED DESCRIBED PARCEL(S) OF LAND ON 9/12/2022, THAT THE ERROR OF CLOSURE IS NO GREATER THAN 1 IN 5000, AND THE SURVEY IS IN FULL COMPLIANCE WITH SECTION NO. 3, ACT 132, P.A. 1970.

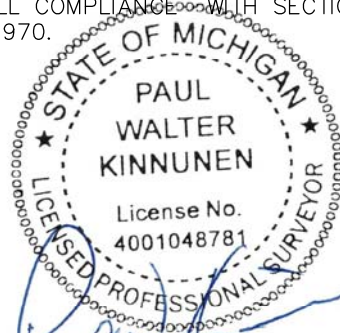

SEPTEMBER 13, 2022

PAUL W. KINNUNEN
PROFESSIONAL SURVEYOR NO. 4001048781
EMAIL: PAUL@GREENTECHENGINEERING.NET

NOTE:

LEGAL DESCRIPTION FOR EXISTING PARCEL NO. 77-071-99-0002-701 AS PROVIDED BY THE CLIENT, FROM DAVID C. ADAMS & SON ATLA/NSPS LAND TITLE SURVEY, DATED NOVEMBER 16, 2017, DCA SURVEY NO. 20199, REMAINDER 'A' PARCEL DESCRIPTION.



CIVIL ENGINEERS & LAND SURVEYORS

51147 W. Pontiac Trail
Wixom, MI 48393
Phone: (248) 668-0700
Fax: (248) 668-0701

CLIENT:	NORTHVILLE LUMBER		DATE: 9-12-2022
	PARCEL SPLIT		DRAWN BY: PWK
	PARCEL NO. 77-071-99-0002-701		CHECKED BY: DJL
	SECTION: 18 TOWNSHIP: 01S. RANGE: 08E.		0 200 400
	NORTHVILLE TOWNSHIP		FBK: -- 3/3
	WAYNE COUNTY		CHF: MM
	MICHIGAN		SCALE HOR 1"= 400FT. VER 1"= -- FT.

20-372

PARCELS 6, 7, 8 AND 9

-LAND TITLE SURVEY LEGEND-

---	GAS MAIN
---	WATER MAIN
---	SANITARY SEWER
---	STORM SEWER
---	UG TELEPHONE COMPANY LINE
---	UG ELECTRIC COMPANY LINE
---	OVERHEAD UTILITY LINE
---	MANHOLE
---	CATCH BASIN
---	YARD SIGN
---	UTILITY POLE
---	WATER GATE
---	UNDERGROUND GAS VALVE
---	WATER VALVE
---	FIRE HYDRANT
---	M.S. & MEAS.
---	MEASURED
---	DESCRIBED
---	CHORD
---	C.I.D.
---	INDICATES ROAD SURFACE

-LAND TITLE SURVEY NOTES-

THE LOCATION OF ALL UTILITY MANHOLES SHOWN HEREON ARE FROM FIELD MEASUREMENTS, THE PIPE DIAMETERS, AND IN SOME CASES THE DIRECTION OF LINES RUNNING FROM MANHOLES, HAVE BEEN TAKEN FROM MUNICIPAL AND PUBLIC UTILITY COMPANY RECORDS, WHEN NO SURFACE CHECK WAS POSSIBLE, WE HAVE SHOWN UNDERGROUND UTILITY LINES RUNNING DIRECTLY FROM SURFACE MANHOLE TO SURFACE MANHOLE. IN MOST CASES, THIS MAY NOT BE THE ACTUAL ROUTE OF THESE LINES, WE ASSUME NO RESPONSIBILITY AS TO THE SIZE OR LOCATION OF UNDERGROUND UTILITIES.

THIS SURVEY HAS BEEN BASED ON FIRST AMERICAN TITLE INSURANCE COMPANY, FILE NO. 793802, DATED SEPTEMBER 8, 2017.

THE BEARINGS SHOWN HEREON ARE BASED ON THE MICHIGAN STATE PLANE COORDINATE SYSTEM, SOUTH ZONE.

PORTIONS OF THE SURVEYED PROPERTY SHOWN HEREON LIE WITHIN A SPECIAL FLOOD HAZARD AREA AS PER THE NATIONAL FLOOD INSURANCE PROGRAM, FLOOD INSURANCE RATE MAP NUMBER 26163C0202E, DATED FEBRUARY 2, 2012.

THERE ARE NO VISIBLE ON SITE PARKING SPACES ON THE SUBJECT PARCEL.

THERE IS NO OBSERVED EVIDENCE OF CURRENT EARTH MOVING WORK, BUILDING CONSTRUCTION OR BUILDING ADDITIONS ON THE SUBJECT PARCELS.

EXCEPTIONS FROM SCHEDULE 'B' OF THE FIRST AMERICAN TITLE INSURANCE COMPANY, FILE NO. 793802, DATED SEPTEMBER 8, 2017:

(6) TERMS AND CONDITIONS CONTAINED IN AFFIDAVIT TO PERMIT RECORDING OF AGREEMENT AS DISCLOSED BY INSTRUMENT RECORDED IN LIBER 40936, PAGE 541, (AFFECTS THE ENTIRE SURVEYED PROPERTY) (NOT PLOTTED ON SURVEY).

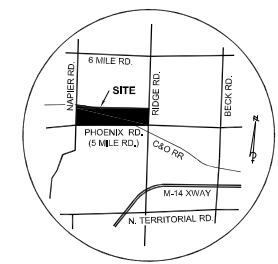

- SITE LOCATION MAP -
SCALE: NONE

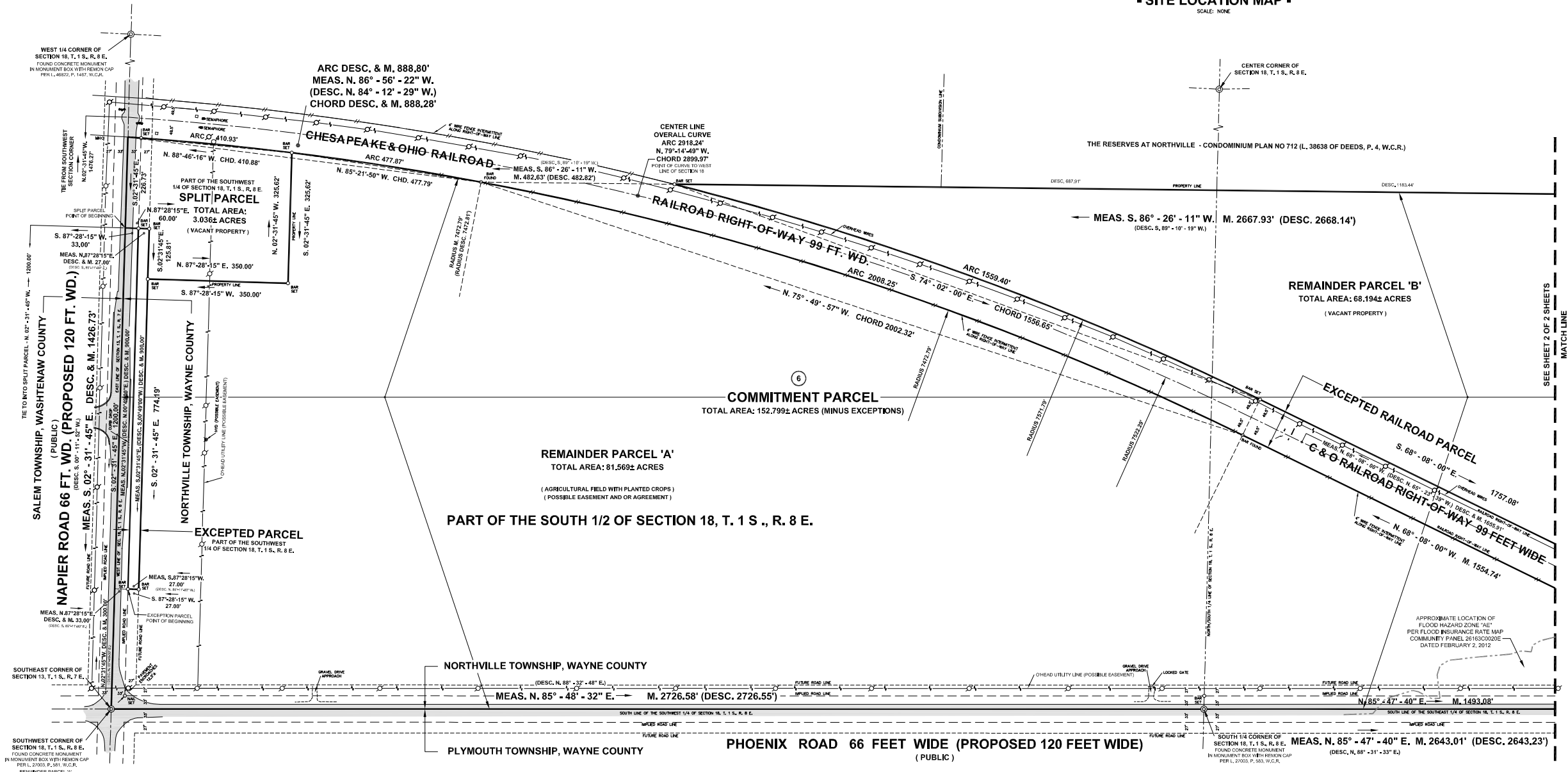

-LAND TITLE SURVEY CERTIFICATION -

TO THE DTE ELECTRIC COMPANY AND FIRST AMERICAN TITLE INSURANCE COMPANY:

THIS IS TO CERTIFY THAT THIS MAP OR PLAN AND THE SURVEY ON WHICH IT IS BASED WERE MADE IN ACCORDANCE WITH THE 2010 MICHIGAN STANDARD DEFINITIVE REQUIREMENTS OF ALL PROPERTY LAND TITLE SURVEYS, WHICH I HAVE READ AND ADOPTED BY ALTA AND NSIP, AND INCLUDES ITEMS 1, 2, 3, 4, 7(A), 8, 9, 11, 12, 13, 14, 16, AND 17 OF TABLE A THEREOF. THE FIELD WORK WAS COMPLETED ON NOVEMBER 9, 2017.

DATED OF PLAN OR MAP: NOVEMBER 16, 2017



DAVID C. ADAMS & SON
PROFESSIONAL LAND SURVEYORS, INC.
2807 E. MICHIGAN
Farmington Hills, MI 48334
Tel: 248-464-2222
Fax: 248-464-2222
www.dcasurvey.com



DCA SURVEY NO. 20199
SHEET 1 OF 2 SHEETS

David C. Adams & Son
Professional Land Surveyors, Inc.
2807 E. Michigan
Farmington Hills, MI 48334
Tel: 248-464-2222
Fax: 248-464-2222
www.dcasurvey.com

PROJ. CHG.	PROJ. DR.	PROJ. ENCL.	PROJ. DR.	PROJ. ENCL.	PROJ. DR.	OTHER APPROVALS	DATE	DIVISION	SUPERVISOR	DATE	APPROVED BY	DATE
									DC ADAMS & SON	11/16/17		
											CHECKED BY	DATE
											SURVEY ENGINEER	DATE
											SUPERVISING ENGINEER	DATE
											M. FAIRLESS	DATE
											DIVISION DIRECTOR	DATE

SHEET 1 OF 2 SHEETS

DTE Energy - DTE Electric Company Central Design

ALTA/NSPS LAND TITLE SURVEY
OF PROPERTY BEING PART OF THE
SOUTH 1/2 OF SECTION 18, T. 1 S., R. 8 E.,
NORTHVILLE TOWNSHIP, WAYNE COUNTY, MICHIGAN.

LOCATION NAME: NAPIER ROAD SUBSTATION

SCALE: 1" = 100'

USE PREVIOUS EDITIONS AT OWNERS RISK

DRAWING NUMBER: 6SE-NVL-004

JOB NUMBER: 48841639

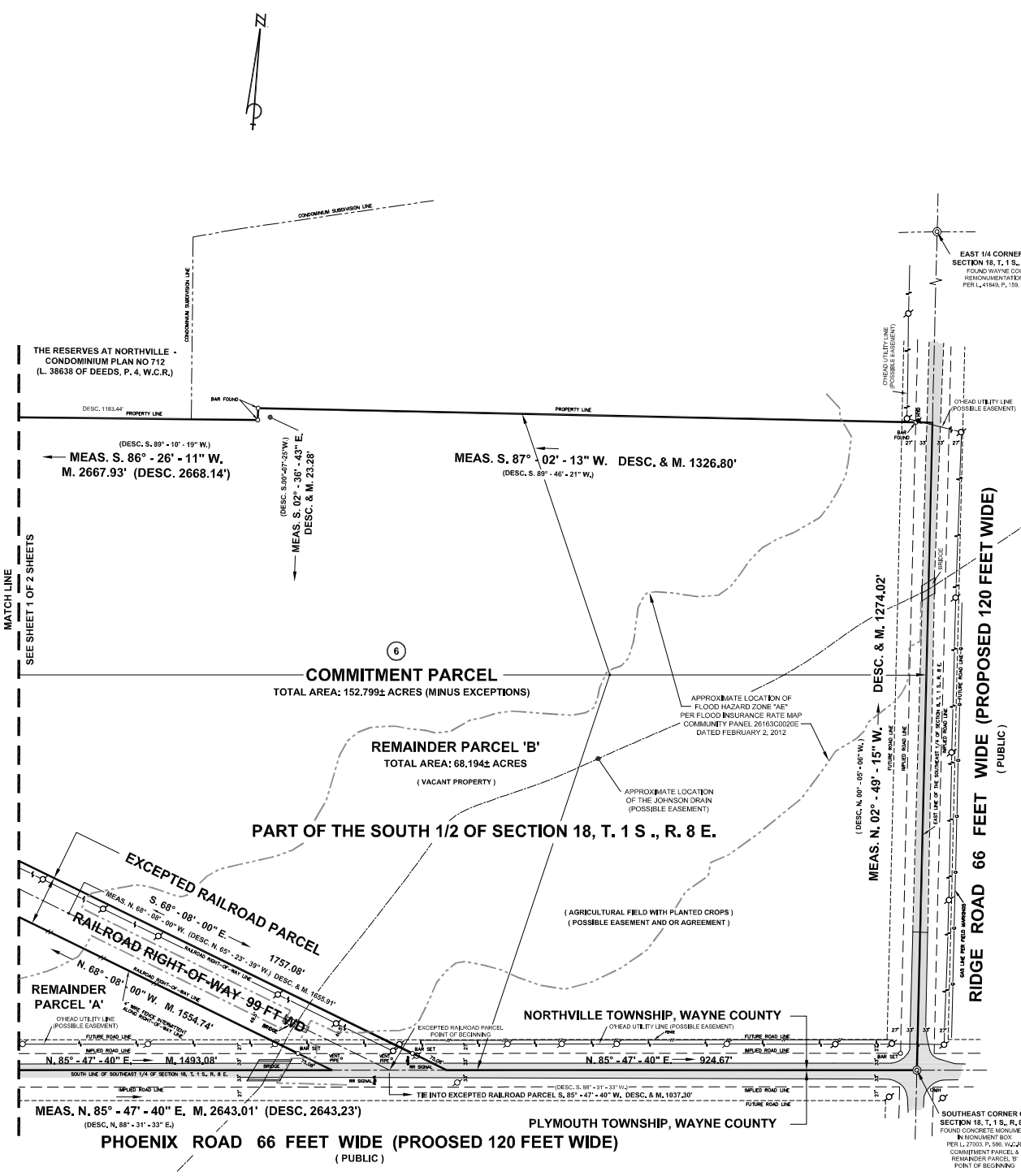

COMMITMENT PARCEL DESCRIPTION FROM SCHEDULE 'C' OF THE FIRST AMERICAN TITLE INSURANCE COMPANY, FILE NO. 793802, DATED SEPTEMBER 8, 2017:
 THE LAND REFERRED TO IN THIS COMMITMENT, SITUATED IN THE COUNTY OF WAYNE, TOWNSHIP OF NORTHVILLE, STATE OF MICHIGAN, IS DESCRIBED AS FOLLOWS:
 PART OF THE SOUTH 1/2 OF SECTION 18, TOWN 1 SOUTH, RANGE 8 EAST, NORTHVILLE TOWNSHIP, WAYNE COUNTY, MICHIGAN, BEING MORE PARTICULARLY DESCRIBED AS FOLLOWS:

BEGINNING AT THE SOUTHWEST CORNER MONUMENT OF SAID SECTION 18, SAID POINT ALSO BEING THE INTERSECTION OF THE CENTERLINE OF PHOENIX ROAD WITH THE CENTERLINE OF RIDGE ROAD; THENCE NORTH 00 DEGREES 05 MINUTES 06 SECONDS WEST 1,274.02 FEET ALONG THE EAST LINE OF SECTION 18 TO A MONUMENT; THENCE SOUTH 89 DEGREES 45 MINUTES 21 SECONDS WEST 1,328.90 FEET TO AN IRON; THENCE SOUTH 00 DEGREES 07 MINUTES 25 SECONDS WEST 2,308 FEET TO AN IRON; THENCE SOUTH 89 DEGREES 10 MINUTES 19 SECONDS WEST 2,668.14 FEET TO AN IRON, SAID IRON BEING ON THE NORTH RIGHT-OF-WAY LINE OF THE C & O RAILROAD; THENCE SOUTH 89 DEGREES 10 MINUTES 19 SECONDS WEST 482.22 FEET TO A POINT ON THE SOUTH RIGHT-OF-WAY LINE OF THE C & O RAILROAD; THENCE ALONG THE SOUTHERLY RIGHT-OF-WAY LINE OF THE RAILROAD 888.85 FEET ALONG AN ARC OF A 7,472.81 FOOT RADIUS CURVE, CONCAVE NORTH WITH A CHORD OF 888.28 FEET BEARING NORTH 04 DEGREES 12 MINUTES 29 SECONDS WEST TO A POINT, SAID POINT BEING THE INTERSECTION OF THE SOUTH RIGHT-OF-WAY LINE OF THE C & O RAILROAD AND THE WEST SECTION LINE OF SECTION 18; THENCE SOUTH 00 DEGREES 11 MINUTES 52 SECONDS WEST 1,428.73 FEET ALONG THE WEST LINE OF SECTION 18 TO A MONUMENT, SAID MONUMENT BEING THE SOUTHWEST SECTION CORNER OF SECTION 18; THENCE NORTH 88 DEGREES 32 MINUTES 48 SECONDS EAST 2,726.55 FEET ALONG THE SOUTH LINE OF SECTION 18 TO A MONUMENT, SAID MONUMENT BEING THE SOUTH 1/4 CORNER OF SECTION 18; THENCE NORTH 88 DEGREES 31 MINUTES 33 SECONDS EAST 2,453.23 FEET ALONG THE SOUTH LINE OF SECTION 18 TO THE POINT OF BEGINNING.

EXCEPTING THEREFROM THE 99 FOOT WIDE RIGHT-OF-WAY OF THE C & O RAILROAD WHICH LIES 49.5 FEET EACH SIDE OF A LINE WHICH IS DESCRIBED AS BEGINNING AT A POINT ON THE SOUTH LINE OF SECTION 18, SOUTH 89 DEGREES 31 MINUTES 33 SECONDS WEST 1,037.20 FEET FROM THE SOUTHWEST CORNER MONUMENT OF SAID SECTION; THENCE NORTH 85 DEGREES 23 MINUTES 39 SECONDS WEST 1,655.91 FEET TO A POINT OF CURVE; THENCE ALONG THE ARC OF A CURVE CONCAVE TO THE NORTH WHOSE RADIUS IS 7,522.29 FEET TO A POINT ON THE WEST LINE OF SECTION 18.

ALSO EXCEPTING THEREFROM THAT PART DESCRIBED AS COMMENCING AT THE SOUTHWEST CORNER OF SECTION 13, TOWN 1 SOUTH, RANGE 7 EAST, SALEM TOWNSHIP, WASHTENAW COUNTY, MICHIGAN, THENCE NORTH 00 DEGREES 49 MINUTES 00 SECONDS EAST 300.00 FEET ALONG THE EAST LINE OF SAID SECTION 13 AND THE CENTER LINE OF NAPIER ROAD; THENCE SOUTH 89 DEGREES 11 MINUTES 00 SECONDS EAST 330.00 FEET TO THE POINT OF BEGINNING; THENCE NORTH 00 DEGREES 49 MINUTES 00 SECONDS EAST 900.00 FEET ALONG THE EAST RIGHT-OF-WAY LINE OF NAPIER ROAD (66.00 FEET TOTAL WIDTH) THENCE SOUTH 89 DEGREES 11 MINUTES 00 SECONDS EAST 27.00 FEET; THENCE SOUTH 00 DEGREES 49 MINUTES 00 SECONDS WEST 900.00 FEET, THENCE NORTH 89 DEGREES 11 MINUTES 00 SECONDS WEST 27.00 FEET TO THE POINT OF BEGINNING, BEING A PART OF THE SOUTHWEST 1/4 OF SECTION 18, TOWN 1 SOUTH, RANGE 8 EAST, NORTHVILLE TOWNSHIP, WAYNE COUNTY, MICHIGAN.

ALL BEING MORE PARTICULARLY DESCRIBED FROM FIELD FINDINGS AS FOLLOWS:

PART OF THE SOUTH 1/2 OF SECTION 18, T. 1 S., R. 8 E., NORTHVILLE TOWNSHIP, WAYNE COUNTY, MICHIGAN, DESCRIBED AS: BEGINNING AT THE SOUTHWEST CORNER OF SAID SECTION 18, SAID POINT ALSO BEING THE INTERSECTION OF THE CENTER LINE OF PHOENIX ROAD (66 FEET WIDE) WITH THE CENTER LINE OF RIDGE ROAD (66 FEET WIDE) AND PROCEEDING THENCE FROM SAID POINT OF BEGINNING NORTH 02 DEGREES 49 MINUTES 15 SECONDS WEST, ALONG THE EAST LINE OF SAID SECTION 18, SAID LINE BEING ALSO THE CENTER LINE OF SAID RIDGE ROAD, A DISTANCE OF 1274.02 FEET TO A POINT; THENCE SOUTH 87 DEGREES 02 MINUTES 13 SECONDS WEST, A DISTANCE OF 1326.80 FEET TO A POINT; THENCE SOUTH 02 DEGREES 38 MINUTES 43 SECONDS EAST, A DISTANCE OF 21.28 FEET TO A POINT; THENCE SOUTH 88 DEGREES 26 MINUTES 11 SECONDS WEST, A MEASURED DISTANCE OF 2697.25 FEET (DESCRIBED 2688.14 FEET) TO A POINT ON THE NORTHERLY RIGHT-OF-WAY LINE OF THE CHESAPEAKE AND OHIO RAILROAD RIGHT-OF-WAY (99 FEET WIDE); THENCE SOUTH 88 DEGREES 26 MINUTES 11 SECONDS WEST, A MEASURED DISTANCE OF 482.63 FEET (DESCRIBED 482.22 FEET) TO A POINT ON THE SOUTHERLY LINE OF SAID CHESAPEAKE AND OHIO RAILROAD RIGHT-OF-WAY; THENCE ALONG SAID SOUTHERLY RAILROAD RIGHT-OF-WAY LINE, ALONG THE ARC OF A CURVE, CONCAVE TO THE SOUTH, A MEASURED RADIUS OF 7472.79 FEET (DESCRIBED 7472.81 FEET), AN ARC DISTANCE OF 888.28 FEET (CHORD BEARS NORTH 04 DEGREES 12 MINUTES 29 SECONDS WEST, 888.28 FEET) TO THE POINT OF INTERSECTION OF SAID RAILROAD RIGHT-OF-WAY LINE WITH THE WEST LINE OF SAID SECTION 18; THENCE SOUTH 02 DEGREES 31 MINUTES 45 SECONDS EAST, ALONG THE WEST LINE OF SAID SECTION 18, SAID LINE BEING ALSO THE CENTER LINE OF NAPIER ROAD (66 FEET WIDE), A DISTANCE OF 1428.73 FEET TO THE SOUTHWEST CORNER OF SAID SECTION 18; THENCE NORTH 88 DEGREES 32 SECONDS EAST, ALONG THE SOUTH LINE OF SAID SECTION 18, SAID LINE BEING ALSO THE CENTER LINE OF PHOENIX ROAD (66 FEET WIDE) TO THE POINT OF BEGINNING; THENCE SOUTH 89 DEGREES 10 MINUTES 19 SECONDS WEST, 2668.14 FEET TO A POINT ON THE WEST LINE OF SAID SECTION 18, SAID POINT BEING NORTH 02 DEGREES 31 MINUTES 45 SECONDS WEST, A DISTANCE OF 1476.27 FEET, AS MEASURED ALONG THE WEST LINE OF SAID SECTION 18, SAID LINE BEING ALSO THE CENTER LINE OF NAPIER ROAD (66 FEET WIDE) FROM THE SOUTHWEST CORNER OF SAID SECTION 18, A DISTANCE OF 2643.23 FEET TO THE POINT OF BEGINNING.

EXCEPTING THEREFROM THE CHESAPEAKE AND OHIO RAILROAD RIGHT OF WAY (99 FEET WIDE), BEING 49.5 FEET EACH SIDE OF A LINE DESCRIBED AS BEGINNING AT A POINT ON THE SOUTH LINE OF SECTION 18, SOUTH 85 DEGREES 47 MINUTES 40 SECONDS WEST, A DISTANCE OF 1037.20 FEET, AS MEASURED ALONG THE SOUTH LINE OF SAID SECTION 18, SAID LINE BEING ALSO THE CENTER LINE OF PHOENIX ROAD (66 FEET WIDE) FROM THE SOUTHWEST CORNER OF SAID SECTION 18; PROCEEDING THENCE FROM SAID POINT OF BEGINNING NORTH 89 DEGREES 08 MINUTES 00 SECONDS WEST, A DISTANCE OF 1559.81 FEET TO A POINT OF CURVE; THENCE ALONG THE ARC OF A CURVE CONCAVE TO THE SOUTH, RADIUS 7522.29 FEET, AN ARC DISTANCE OF 2918.24 FEET (CHORD BEARS NORTH 79 DEGREES 14 MINUTES 49 SECONDS WEST, 2909.81 FEET) TO A POINT ON THE WEST LINE OF SAID SECTION 18, SAID POINT BEING NORTH 02 DEGREES 31 MINUTES 45 SECONDS WEST, A DISTANCE OF 1476.27 FEET, AS MEASURED ALONG THE WEST LINE OF SAID SECTION 18, SAID LINE BEING ALSO THE CENTER LINE OF NAPIER ROAD (66 FEET WIDE) FROM THE SOUTHWEST CORNER OF SAID SECTION 18, A DISTANCE OF 226.73 FEET TO THE POINT OF BEGINNING.

ALSO EXCEPTING THEREFROM THAT PART OF THE SOUTHWEST 1/4 OF SECTION 18, T. 1 S., R. 8 E., NORTHVILLE TOWNSHIP, WAYNE COUNTY, MICHIGAN DESCRIBED AS COMMENCING AT THE SOUTHWEST CORNER OF SECTION 18, T. 1 S., R. 8 E., NORTHVILLE TOWNSHIP, WAYNE COUNTY, MICHIGAN, SAID POINT BEING ALSO THE SOUTHWEST CORNER OF SECTION 13, T. 1 S., R. 7 E., SALEM TOWNSHIP, WASHTENAW COUNTY, MICHIGAN, AND RUNNING THENCE NORTH 02 DEGREES 31 MINUTES 45 SECONDS WEST, ALONG THE WEST LINE OF SAID SECTION 18, SAID LINE BEING ALSO THE CENTER LINE OF NAPIER ROAD (66 FEET WIDE), A DISTANCE OF 300.00 FEET TO A POINT; THENCE NORTH 87 DEGREES 02 MINUTES 13 SECONDS EAST, A DISTANCE 33.00 FEET TO THE POINT OF BEGINNING; PROCEEDING THENCE FROM SAID POINT OF BEGINNING NORTH 02 DEGREES 31 MINUTES 45 SECONDS WEST, ALONG A LINE, 33.00 FEET EAST OF, AS MEASURED AT RIGHT ANGLES TO AND PARALLEL WITH THE WEST LINE OF SAID SECTION 18, A DISTANCE OF 800.00 FEET TO A POINT; THENCE NORTH 87 DEGREES 28 MINUTES 15 SECONDS EAST, A DISTANCE OF 217.00 FEET TO A POINT; THENCE SOUTH 02 DEGREES 31 MINUTES 45 SECONDS EAST, ALONG A LINE 60.00 FEET EAST OF, AS MEASURED AT RIGHT ANGLES TO AND PARALLEL WITH THE WEST LINE OF SAID SECTION 18, A DISTANCE OF 900.00 FEET TO A POINT; THENCE SOUTH 87 DEGREES 28 MINUTES 15 SECONDS WEST, A DISTANCE OF 27.00 FEET TO THE POINT OF BEGINNING.

SPLIT PARCEL DESCRIPTION:
 PART OF THE SOUTHWEST 1/4 OF SECTION 18, T. 1 S., R. 8 E., NORTHVILLE TOWNSHIP, WAYNE COUNTY, MICHIGAN AND BEING MORE PARTICULARLY DESCRIBED AS FOLLOWS:
 BEGINNING AT A POINT ON THE WEST LINE OF SECTION 18, T. 1 S., R. 8 E., NORTHVILLE TOWNSHIP, WAYNE COUNTY, MICHIGAN, DISTANT NORTH 02 DEGREES 31 MINUTES 45 SECONDS WEST 1200.00 FEET, AS MEASURED ALONG THE WEST LINE OF SAID SECTION 18, SAID LINE BEING ALSO THE CENTER LINE OF NAPIER ROAD (66 FEET WIDE) FROM THE SOUTHWEST CORNER OF SAID SECTION 18; PROCEEDING THENCE FROM SAID POINT OF BEGINNING NORTH 87 DEGREES 28 MINUTES 15 SECONDS EAST, A DISTANCE OF 60.00 FEET TO A POINT; THENCE SOUTH 02 DEGREES 31 MINUTES 45 SECONDS EAST, ALONG A LINE, 60 FEET EAST OF, AS MEASURED AT RIGHT ANGLES TO AND PARALLEL WITH THE WEST LINE OF SAID SECTION 18, A DISTANCE OF 125.81 FEET TO A POINT; THENCE NORTH 02 DEGREES 28 MINUTES 15 SECONDS EAST, A DISTANCE OF 350.00 FEET TO A POINT; THENCE NORTH 02 DEGREES 31 MINUTES 45 SECONDS WEST, A DISTANCE OF 325.62 FEET TO A POINT ON THE SOUTHERLY LINE OF THE CHESAPEAKE AND OHIO RAILROAD RIGHT-OF-WAY (99 FEET WIDE); THENCE ALONG THE SOUTHERLY RAILROAD RIGHT-OF-WAY LINE, ALONG THE ARC OF A CURVE, CONCAVE TO THE SOUTH, RADIUS 7472.79 FEET, AN ARC DISTANCE OF 410.93 FEET (CHORD BEARS NORTH 88 DEGREES 40 MINUTES 45 SECONDS WEST, 410.88 FEET) TO THE POINT OF INTERSECTION OF SAID RIGHT-OF-WAY LINE WITH THE WEST LINE OF SAID SECTION 18; THENCE SOUTH 02 DEGREES 31 MINUTES 45 SECONDS EAST, ALONG THE WEST LINE OF SAID SECTION 18, A DISTANCE OF 226.73 FEET TO THE POINT OF BEGINNING, SUBJECT TO THE RIGHTS OF THE PUBLIC OVER THE WESTERLY 33 FEET THEREOF FOR ROAD PURPOSES (NAPIER ROAD).

REMAINDER 'A' PARCEL DESCRIPTION:
 PART OF THE SOUTH 1/2 OF SECTION 18, T. 1 S., R. 8 E., NORTHVILLE TOWNSHIP, WAYNE COUNTY, MICHIGAN AND BEING MORE PARTICULARLY DESCRIBED AS FOLLOWS; BEGINNING AT THE SOUTHWEST CORNER OF SECTION 18, T. 1 S., R. 8 E., NORTHVILLE TOWNSHIP, WAYNE COUNTY, MICHIGAN AND PROCEEDING THENCE FROM SAID POINT OF BEGINNING NORTH 85 DEGREES 48 MINUTES 32 SECONDS EAST, ALONG THE SOUTH LINE OF SAID SECTION 18, SAID LINE BEING ALSO THE CENTER LINE OF PHOENIX ROAD (66 FEET WIDE); A MEASURED DISTANCE OF 2726.58 FEET (DESCRIBED 2726.55 FEET) TO THE SOUTH 1/4 CORNER OF SAID SECTION 18; THENCE NORTH 85 DEGREES 47 MINUTES 40 SECONDS EAST, CONTINUING ALONG THE SOUTH LINE OF SAID SECTION 18 AND THE CENTER LINE OF SAID PHOENIX ROAD, A DISTANCE OF 1493.08 FEET TO THE POINT OF INTERSECTION OF SAID SECTION LINE WITH THE SOUTHERLY LINE OF THE CHESAPEAKE AND OHIO RAILROAD RIGHT-OF-WAY (99 FEET WIDE); THENCE NORTH 88 DEGREES 08 MINUTES 00 SECONDS WEST, ALONG SAID SOUTHERLY RAILROAD RIGHT-OF-WAY LINE, A DISTANCE OF 1504.91 FEET TO A POINT OF CURVE IN SAID RIGHT-OF-WAY LINE; THENCE CONCAVE ALONG SAID RAILROAD RIGHT-OF-WAY LINE, ALONG THE ARC OF A CURVE, CONCAVE TO THE SOUTH, RADIUS 7472.79 FEET, AN ARC DISTANCE OF 2008.25 FEET, (CHORD BEARS NORTH 75 DEGREES 49 MINUTES 57 SECONDS WEST, 2002.32 FEET) TO A POINT; THENCE CONTINUING ALONG SAID SOUTHERLY RAILROAD RIGHT-OF-WAY LINE, ALONG THE ARC OF A CURVE, CONCAVE TO THE SOUTH, RADIUS 7472.79 FEET, AN ARC DISTANCE OF 471.87 FEET, (CHORD BEARS NORTH 04 DEGREES 21 MINUTES 50 SECONDS WEST, 471.79 FEET) TO A POINT; THENCE SOUTH 02 DEGREES 31 MINUTES 45 SECONDS EAST, A DISTANCE OF 325.62 FEET TO A POINT; THENCE SOUTH 87 DEGREES 28 MINUTES 15 SECONDS WEST, A DISTANCE OF 350.00 FEET TO A POINT; THENCE SOUTH 02 DEGREES 31 MINUTES 45 SECONDS EAST, ALONG A LINE 60.00 FEET EAST OF, AS MEASURED AT RIGHT ANGLES TO AND PARALLEL WITH THE WEST LINE OF SAID SECTION 18, A DISTANCE OF 774.19 FEET TO A POINT; THENCE SOUTH 87 DEGREES 28 MINUTES 15 SECONDS WEST, A DISTANCE OF 27.00 FEET TO A POINT; THENCE NORTH 02 DEGREES 31 MINUTES 45 SECONDS WEST, ALONG THE WEST LINE OF SAID SECTION 18, A DISTANCE OF 1504.91 FEET TO A POINT; THENCE SOUTH 02 DEGREES 31 MINUTES 45 SECONDS WEST, A DISTANCE OF 900.00 FEET TO A POINT; THENCE SOUTH 87 DEGREES 28 MINUTES 15 SECONDS WEST, A DISTANCE OF 33.00 FEET TO A POINT ON THE WEST LINE OF SAID SECTION 18; THENCE SOUTH 02 DEGREES 31 MINUTES 45 SECONDS EAST, ALONG THE WEST LINE OF SAID SECTION 18, SAID LINE BEING ALSO THE CENTER LINE OF NAPIER ROAD (66 FEET WIDE), A DISTANCE 1200.00 FEET TO THE POINT OF BEGINNING, THE ABOVE DESCRIBED PARCEL IS SUBJECT TO THE RIGHTS OF THE PUBLIC OVER THE SOUTHERLY AND WESTERLY 33 FEET THEREOF FOR ROAD PURPOSES (PHOENIX ROAD AND NAPIER ROAD).

REMAINDER 'B' PARCEL DESCRIPTION:
 PART OF THE SOUTH 1/2 OF SECTION 18, T. 1 S., R. 8 E., NORTHVILLE TOWNSHIP, WAYNE COUNTY, MICHIGAN AND BEING MORE PARTICULARLY DESCRIBED AS FOLLOWS; BEGINNING AT THE SOUTHWEST CORNER OF SECTION 18, T. 1 S., R. 8 E., NORTHVILLE TOWNSHIP, WAYNE COUNTY, MICHIGAN AND PROCEEDING THENCE FROM SAID POINT OF BEGINNING NORTH 02 DEGREES 49 MINUTES 15 SECONDS WEST, ALONG THE EAST LINE OF SAID SECTION 18, SAID LINE BEING ALSO THE CENTER LINE OF RIDGE ROAD (66 FEET WIDE), A DISTANCE OF 1274.02 FEET TO A POINT; THENCE SOUTH 87 DEGREES 02 MINUTES 13 SECONDS WEST, A DISTANCE OF 1326.80 FEET TO A POINT; THENCE SOUTH 02 DEGREES 38 MINUTES 43 SECONDS EAST, A DISTANCE OF 21.28 FEET TO A POINT; THENCE SOUTH 88 DEGREES 26 MINUTES 11 SECONDS WEST, A MEASURED DISTANCE OF 2697.25 FEET (DESCRIBED 2688.14 FEET) TO A POINT ON THE NORTHERLY RIGHT-OF-WAY LINE OF THE CHESAPEAKE AND OHIO RAILROAD RIGHT-OF-WAY (99 FEET WIDE); THENCE ALONG SAID NORTHERLY RAILROAD RIGHT-OF-WAY LINE, ALONG THE ARC OF A CURVE, CONCAVE TO THE SOUTH, RADIUS 7472.79 FEET, AN ARC DISTANCE OF 888.28 FEET (CHORD BEARS NORTH 04 DEGREES 12 MINUTES 29 SECONDS WEST, 888.28 FEET) TO THE POINT OF INTERSECTION OF SAID RAILROAD RIGHT-OF-WAY LINE WITH THE WEST LINE OF SAID SECTION 18; THENCE SOUTH 02 DEGREES 31 MINUTES 45 SECONDS EAST, ALONG THE WEST LINE OF SAID SECTION 18, SAID LINE BEING ALSO THE CENTER LINE OF NAPIER ROAD (66 FEET WIDE), A DISTANCE OF 1428.73 FEET TO THE SOUTHWEST CORNER OF SAID SECTION 18; THENCE NORTH 88 DEGREES 32 SECONDS EAST, ALONG THE SOUTH LINE OF SAID SECTION 18, SAID LINE BEING ALSO THE CENTER LINE OF PHOENIX ROAD (66 FEET WIDE), A DISTANCE OF 824.67 FEET TO THE POINT OF BEGINNING, THE ABOVE DESCRIBED PARCEL IS SUBJECT TO THE RIGHTS OF THE PUBLIC OVER THE SOUTHERLY AND EASTERLY 33 FEET THEREOF FOR ROAD PURPOSES (PHOENIX ROAD AND RIDGE ROAD).

NOTE: SEE SHEET 1 OF 2 SHEETS FOR ALTNAPS LAND TITLE SURVEY NOTES AND LEGEND.

DCA SURVEY NO. 20199
 SHEET 2 OF 2 SHEETS
 David C. Adams & Son
 Professional Land Surveyors, Inc.
 2507 E. Main Street
 Detroit, Michigan 48233
 Tel: 313-486-6222
 Fax: 313-486-6438
 www.dcasurvey.com

PROJ. NO.	PROJ. OR.	PROJ. ENCL.	PROJ. DR.	PROJ. DATE	PROJ. DATE	OTHER APPROVALS	DATE	DIVISION	SUPERVISOR	DATE
									DC ADAMS & SON	11/16/17
									CHECKED BY	DATE
									SURVEY ENGINEER	DATE
									SUPERVISING ENGINEER	DATE
									M. FAIRLESS	DATE
									DIVISION DIRECTOR	DATE

SHEET 2 OF 2 SHEETS

DTE Energy - DTE Electric Company Central Design

ALTA/NSPS LAND TITLE SURVEY
 OF PROPERTY BEING PART OF THE
 SOUTH 1/2 OF SECTION 18, T. 1 S., R. 8 E.,
 NORTHVILLE TOWNSHIP, WAYNE COUNTY, MICHIGAN.

LOCATION NAME: NAPIER ROAD SUBSTATION
 SURVEYING SERVICES
 DRAWING NUMBER: 6SE-NVL-004
 JOB NUMBER: 48841639

SCALE: 1" = 100'
 USE DIMENSIONS ON THIS SCALE

PARCEL 10

MITC PARCEL 10
PROPERTY SKETCH AND LEGAL DESCRIPTION

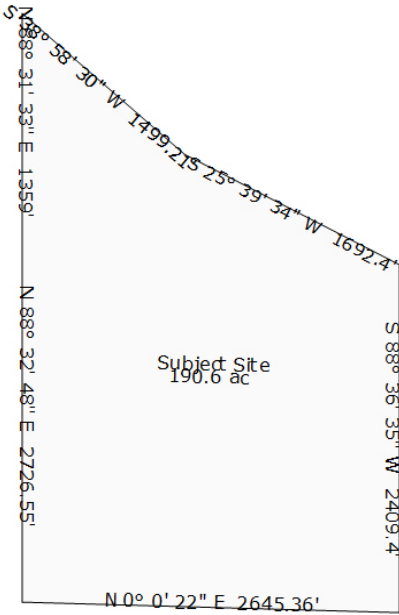

A PARCEL OF LAND IN THE N 1/2 OF SEC 19 T1S R8E DESC AS BEG S 88D 31M 33S W 1284.22 FT FROM NE COR OF SAID SECTION TH S 38D 58M 31S W 1499.20 FT; TH S 25D 39M 34S W 1692.40 FT; TH S 88D 36M 35S W 2409.40 FT; TH N 00D 00M 22S E 2645.36 FT; TH N 88D 32M 48S E 2726.55 FT; TH N 88D 31M 33S E 1359.00 FT POB NET ACRES = 186.50 AC OF LAND, MORE OR LESS ROAD AREA = 4.07 AC OF LAND, MORE OR LESS TOTAL AREA = 190.57 AC OF LAND, MORE OR LESS SUBJECT TO EASEMENTS OF RECORD -----
 ----- SPLIT ON 02/12/2009 FROM R-78-001-99-0001-702 CREATING 78-001-99-0001-703 & 78-001-99-0001-704

PARCEL 11/12

BENCHMARKS
(GPS DERIVED - NAVD88)

BM #301
NORTH RIM OF SANITARY MANHOLE, EAST 30.55 FEET FROM THE CENTERLINE OF RIDGE ROAD AND SOUTH 38.00 FEET FROM THE CENTERLINE OF 5 MILE ROAD.
ELEV. - 841.48

BM #302
NORTH RIM OF SANITARY MANHOLE, EAST 33.00 FEET FROM THE CENTERLINE OF RIDGE ROAD AND NORTH 364.00 FEET FROM THE EAST 1/4 POST.
ELEV. - 844.05

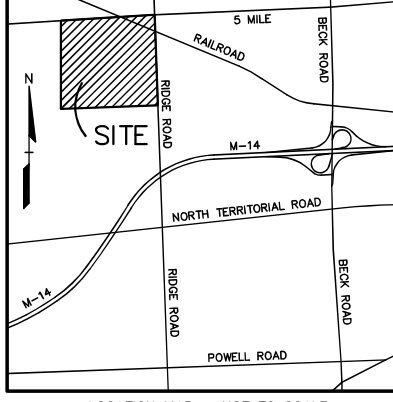
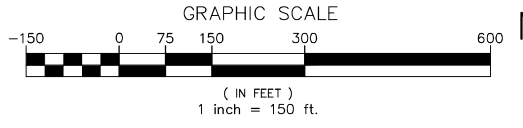

NO.	DATE	BY	DESCRIPTION
1	05/20/18	JL	FINAL SITE PLAN
2	05/22/18	JL	W.C.D.P.D.S. COMMENTS
3	05/23/18	JL	W.C.D.P.D.S. COMMENTS
4	05/23/18	JL	W.C.D.P.D.S. COMMENTS
5	05/23/18	JL	W.C.D.P.D.S. COMMENTS
6	05/23/18	JL	W.C.D.P.D.S. COMMENTS
7	05/23/18	JL	W.C.D.P.D.S. COMMENTS
8	05/23/18	JL	W.C.D.P.D.S. COMMENTS
9	05/23/18	JL	W.C.D.P.D.S. COMMENTS
10	05/23/18	JL	W.C.D.P.D.S. COMMENTS



CAUTION!
THE LOCATIONS AND ELEVATIONS OF EXISTING UNDERGROUND UTILITIES AS SHOWN ON THIS DRAWING ARE ONLY APPROXIMATE. NO GUARANTEE IS EITHER EXPRESSED OR IMPLIED AS TO THE COMPLETENESS OR ACCURACY THEREOF. THE CONTRACTOR SHALL BE SOLELY RESPONSIBLE FOR DETERMINING THE EXACT UTILITY LOCATIONS AND ELEVATIONS PRIOR TO THE START OF CONSTRUCTION.

THIS DRAWING AND DESIGN ARE THE PROPERTY OF PEA, INC. AND ARE SUBMITTED ON THE CONDITION THAT THEY ARE NOT TO BE USED, REPRODUCED, OR COPIED, WHOLLY OR IN PART, OR USED FOR ANY OTHER PROJECT WITHOUT THE WRITTEN CONSENT OF PEA, INC. COMMON LAW RIGHTS OF COPYRIGHT AND OTHERWISE ARE HEREBY SPECIFICALLY RESERVED. © 2018 PEA, INC.

CONSTRUCTION CONTRACTOR AGREES THAT IN ACCORDANCE WITH GENERALLY ACCEPTED CONSTRUCTION PRACTICES, CONSTRUCTION CONTRACTOR WILL BE REQUIRED TO ASSUME SOLE AND COMPLETE RESPONSIBILITY FOR ASBESTOS CONDITIONS DURING THE COURSE OF CONSTRUCTION OF THE PROJECT. THE EMPLOYER AND ALL PERSONS EMPLOYED BY THE EMPLOYER SHALL BE MADE TO APPLY CONTINUOUSLY AND NOT BE LIMITED TO ASBESTOS AND OTHER HAZARDOUS MATERIALS. CONTRACTOR FURTHER AGREES TO DEFEND, INDEMNIFY AND HOLD HARMLESS THE DESIGN PROFESSIONAL FROM AND ALL LIABILITY, REAL OR ALLEGED, IN CONNECTION WITH THE PERFORMANCE OF WORK ON THIS PROJECT EXCEPTING LIABILITY ARISING FROM THE SOLE NEGLIGENCE OF THE DESIGN PROFESSIONAL.

3 FULL WORKING DAYS BEFORE YOU DIG CALL 811
Know what's below
Call before you dig
MISS DIG System, Inc.
1-800-482-7171 www.missdig.org



PEA, Inc.
2430 Rochester Ct., Ste. 100
Troy, MI 48063-1872
T: 248.689.3000
F: 248.689.1044
www.peainc.com

HILLSIDE REALTY INVESTMENTS, LLC
39475 W. 13 MILE RD., SUITE 203
NOVI, MICHIGAN 48377

OVERALL EXISTING CONDITIONS PLAN
RIDGE ROAD INDUSTRIAL PARK
PART OF THE NORTH 1/2 OF SECTION 19, TOWNSHIP 19 NORTH, RANGE 8 EAST, PLYMOUTH TOWNSHIP, WAYNE COUNTY, MICHIGAN

DES: JEC DN JEC SUR TS P.M. BK
JEC DN JEC SUR TS P.M. BK

ORIGINAL ISSUE DATE: FEBRUARY 26, 2019
PEA JOB NO. 2018-234
SCALE: 1" = 150'
DRAWING NUMBER: C-1.0

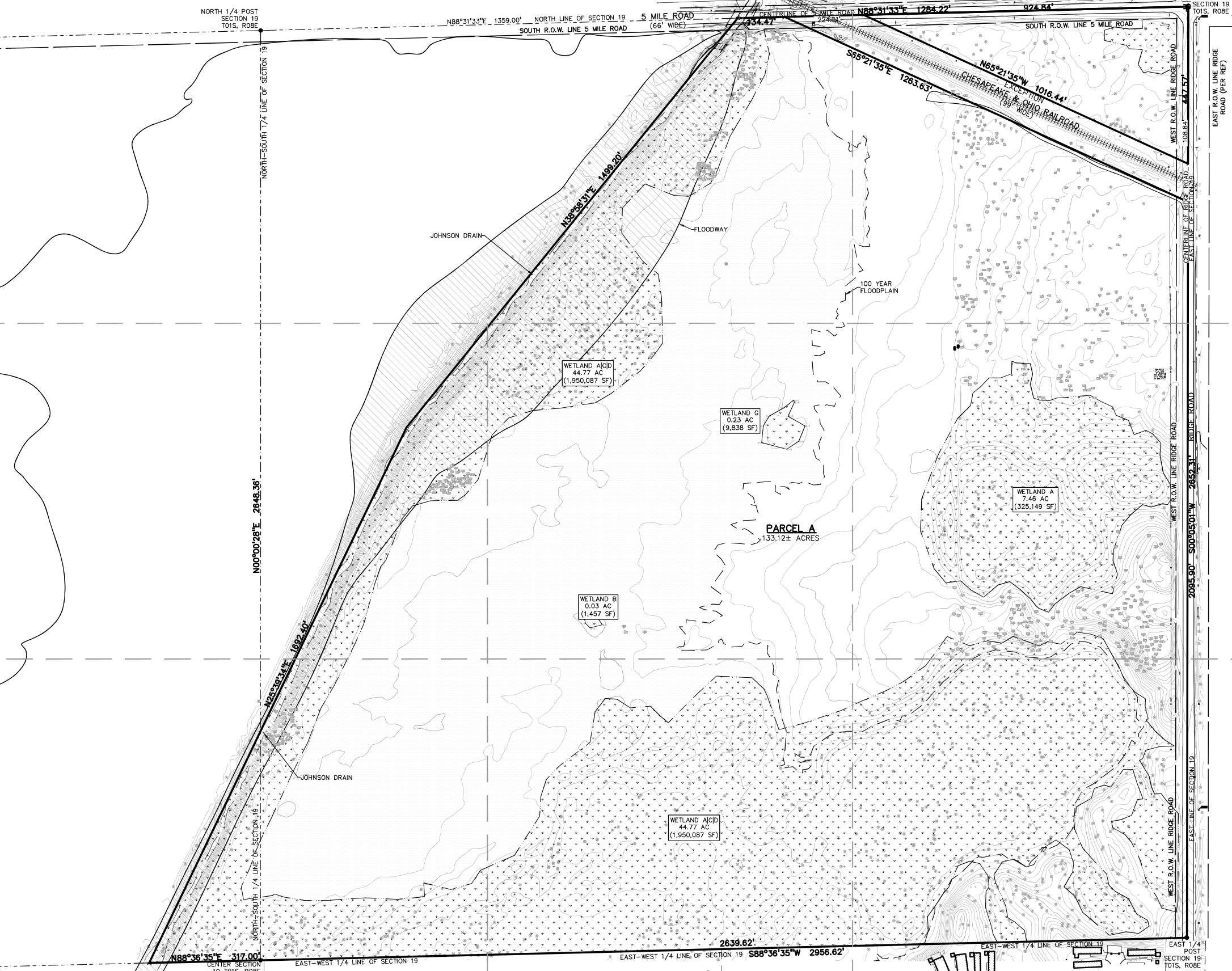

LEGAL DESCRIPTION
(PER SURVEY PROVIDED BY STANTEC CONSULTING, PROJECT NO. 2075105700, DATED JUNE 25, 2007)

PARCEL A
A PARCEL OF LAND LYING EASTERLY OF JOHNSON CREEK IN THE NORTH 1/2 OF SECTION 19, TOWN 1 SOUTH, RANGE 8 EAST, PLYMOUTH TOWNSHIP, WAYNE COUNTY, MICHIGAN, AND BEING MORE SPECIFICALLY DESCRIBED AS BEGINNING AT THE NORTHEAST CORNER OF SAID SECTION 19; THENCE SOUTH 00 DEGREES 05'01" WEST 2652.31 FEET ALONG THE EAST LINE OF SAID SECTION 19 AND THE CENTERLINE OF RIDGE ROAD TO THE EAST AND WEST 1/4 LINE OF SAID SECTION 19; THENCE SOUTH 88 DEGREES 36'35" WEST, 2956.62 FEET ALONG THE EAST AND WEST 1/4 LINE TO AN INTERMEDIATE TRAVERSE LINE OF THE CENTERLINE OF JOHNSON CREEK; THENCE NORTH 25 DEGREES 39'34" EAST, 1692.40 FEET ALONG THE INTERMEDIATE TRAVERSE LINE OF JOHNSON CREEK; THENCE NORTH 38 DEGREES 58'31" EAST, 1499.20 FEET ALONG THE INTERMEDIATE TRAVERSE LINE OF JOHNSON CREEK TO THE NORTH LINE OF SAID SECTION 19 AND THE CENTERLINE OF FIVE MILE ROAD; THENCE NORTH 88 DEGREES 31'33" EAST, 1284.22 FEET ALONG THE NORTH LINE OF SAID SECTION 19 AND THE CENTERLINE OF FIVE MILE ROAD TO THE EAST LINE OF SAID SECTION 19 AND THE POINT OF BEGINNING.

EXCEPTING A PARCEL OF LAND OWNED BY THE CHESAPEAKE AND OHIO RAILROAD, LYING IN THE NORTH 1/2 OF SECTION 19, TOWN 1 SOUTH, RANGE 8 EAST, PLYMOUTH TOWNSHIP, WAYNE COUNTY, MICHIGAN, AND BEING MORE SPECIFICALLY DESCRIBED AS COMMENCING AT THE NORTHEAST CORNER OF SAID SECTION 19; THENCE SOUTH 00 DEGREES 05'01" WEST, 447.57 FEET ALONG THE EAST LINE OF SAID SECTION 19 AND THE CENTERLINE OF RIDGE ROAD FOR THE POINT OF BEGINNING OF THIS EXCEPTION DESCRIPTION; THENCE CONTINUING SOUTH 00 DEGREES 05'01" WEST, 108.84 FEET ALONG THE EAST LINE OF SAID SECTION 19 AND THE CENTERLINE OF RIDGE ROAD; THENCE NORTH 65 DEGREES 21'35" WEST, 1263.63 FEET TO THE NORTH LINE OF SAID SECTION 19 AND THE CENTERLINE OF FIVE MILE ROAD; THENCE NORTH 88 DEGREES 31'33" EAST, 224.91 FEET ALONG THE NORTH LINE OF SAID SECTION 19 AND THE CENTERLINE OF FIVE MILE ROAD; THENCE SOUTH 65 DEGREES 21'35" EAST, 1016.44 FEET TO THE EAST LINE OF SAID SECTION 19 AND THE POINT OF BEGINNING.

CONTAINING 133.12 ACRES OF LAND, MORE OR LESS. SUBJECT TO EASEMENTS, RESTRICTIONS AND OTHER PERTINENT INSTRUMENTS.

REMAINDER
A PARCEL OF LAND LYING WESTERLY OF JOHNSON CREEK IN THE NORTH 1/2 OF SECTION 19, TOWN 1 SOUTH, RANGE 8 EAST, PLYMOUTH TOWNSHIP, WAYNE COUNTY, MICHIGAN, AND BEING MORE SPECIFICALLY DESCRIBED AS COMMENCING AT THE NORTHEAST CORNER OF SAID SECTION 19; THENCE SOUTH 88 DEGREES 31'33" WEST, 1284.22 FEET ALONG THE NORTH LINE OF SAID SECTION 19 AND THE CENTERLINE OF FIVE MILE ROAD TO AN INTERMEDIATE TRAVERSE LINE OF THE CENTERLINE OF JOHNSON CREEK FOR THE POINT OF BEGINNING OF THIS DESCRIPTION; THENCE SOUTH 38 DEGREES 58'31" WEST, 1499.20 FEET ALONG THE INTERMEDIATE TRAVERSE LINE OF JOHNSON CREEK; THENCE SOUTH 25 DEGREES 39'34" WEST, 1692.40 FEET ALONG THE INTERMEDIATE TRAVERSE LINE OF JOHNSON CREEK TO THE EAST AND WEST 1/4 LINE OF SAID SECTION 19; THENCE SOUTH 88 DEGREES 36'35" WEST, 2409.40 FEET ALONG THE EAST AND WEST 1/4 LINE TO THE WEST LINE OF SAID SECTION 19; THENCE NORTH 00 DEGREES 00'22" EAST, 2645.36 FEET ALONG THE WEST LINE OF SAID SECTION 19 TO THE NORTH LINE OF SAID SECTION 19 AND THE CENTERLINE OF FIVE MILE ROAD; THENCE NORTH 88 DEGREES 32'48" EAST, 2726.55 FEET ALONG THE NORTH LINE OF SAID SECTION 19 AND THE CENTERLINE OF FIVE MILE ROAD TO THE NORTH AND SOUTH 1/4 LINE OF SAID SECTION 19; THENCE NORTH 88 DEGREES 31'33" EAST, 1359.00 FEET ALONG THE NORTH LINE OF SAID SECTION 19 AND THE CENTERLINE OF FIVE MILE ROAD TO THE POINT OF BEGINNING.

CONTAINING 190.57 ACRES OF LAND, MORE OR LESS. SUBJECT TO EASEMENTS, RESTRICTIONS AND OTHER PERTINENT INSTRUMENTS.

W.C.D.P.D.S. # R19-146
NOT FOR CONSTRUCTION

PARCEL 13 AND PARCEL 15

Lot Division

Existing Parcel ID	78-006-99-0001-701
New Parcel ID	78-006-99-0001-710, Parcel A
New Parcel ID	78-006-99-0001-711. Parcel B

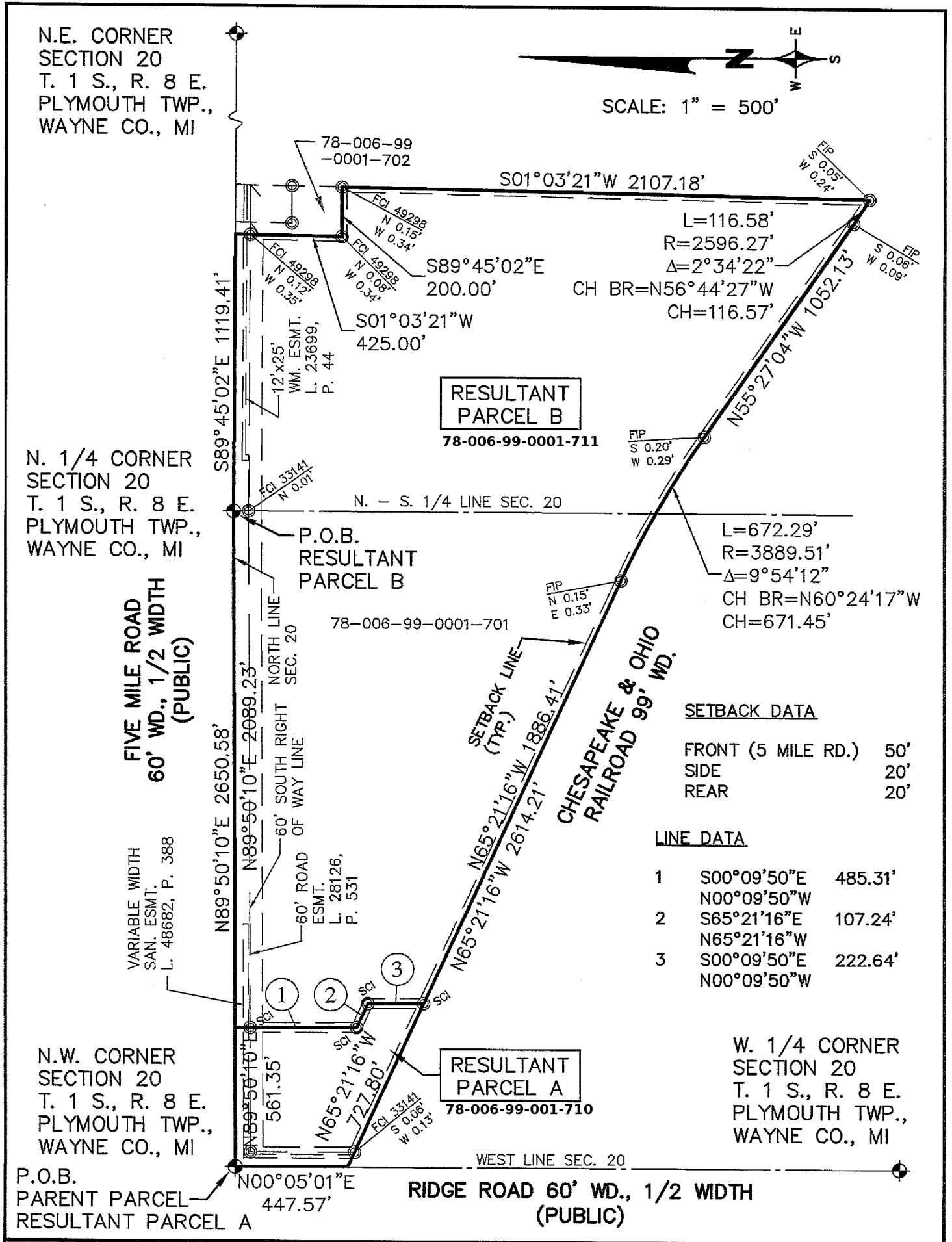

REVISIONS		
ITEM	DATE	BY
ADD SETBACKS	3-27-18	PTG

Z EIMET W OZNIAK
& ASSOCIATES

PARCEL SPLIT

PLYMOUTH TOWNSHIP, WAYNE COUNTY, MICHIGAN

DATE	3-20-18	SCALE	HOR: 1" = 500'
DESIGNED BY	RH	FIELD BOOK NO.	
DRAWN BY	PTG	JOB NO.	17157
		SHEET NO.	1/3

© COPYRIGHT 2018

LEGAL DESCRIPTION (PARENT PARCEL)

A PARCEL OF LAND IN THE NORTH 1/2 OF SECTION 20, TOWN 1 SOUTH – RANGE 8 EAST PLYMOUTH TOWNSHIP, WAYNE COUNTY, MICHIGAN, MORE PARTICULARLY DESCRIBED AS BEGINNING AT THE NORTHWEST CORNER OF SAID SECTION 20; THENCE N. 89°50'10" E. 2650.58 FEET ON THE NORTH LINE OF SAID SECTION TO THE NORTH 1/4 CORNER OF SAID SECTION; THENCE CONTINUING ON SAID NORTH LINE S. 89°45'02" E. 1119.41 FEET; THENCE S. 01°03'21" W. 425.00 FEET; THENCE S. 89°45'02" E. 200.00 FEET; THENCE S. 01°03'21" W. 2107.18 FEET TO THE NORTHERLY RIGHT OF WAY OF THE CHESAPEAKE AND OHIO RAILROAD; THENCE ALONG SAID NORTHERLY RIGHT OF WAY THE FOLLOWING FOUR (4) COURSES: 1) 116.58 FEET ON A CURVE TO THE RIGHT WITH A RADIUS OF 2596.27 FEET, A CENTRAL ANGLE OF 02°34'22" AND A CHORD THAT BEARS N. 56°44'27" W. 116.57 FEET, 2) N. 55°27'04" W. 1052.13 FEET, 3) 672.29 FEET ON A CURVE TO THE LEFT WITH A RADIUS OF 3889.51 FEET, A CENTRAL ANGLE OF 09°54'12" AND A CHORD THAT BEARS N. 60°24'17" W. 671.45 FEET AND 4) N. 65°21'16" W. 2614.21 FEET TO THE WEST LINE OF SAID SECTION 20; THENCE N. 00°05'01" E. 447.57 FEET ON SAID WEST LINE TO THE POINT OF BEGINNING, CONTAINING 5,458,726 SQUARE FEET OR 125.32 ACRES OF LAND MORE OR LESS.

LEGAL DESCRIPTION (RESULTANT PARCEL 'A')

A PARCEL OF LAND LOCATED IN THE NORTH 1/2 OF SECTION 20, T. 1 S., R. 8 E., PLYMOUTH TOWNSHIP, WAYNE COUNTY, MICHIGAN, MORE PARTICULARLY DESCRIBED AS: COMMENCING AT THE NORTHWEST CORNER OF SAID SECTION 20; THENCE N. 89°50'10" E. 561.35 FEET ALONG THE NORTH LINE OF SAID SECTION, ALSO BEING THE CENTERLINE OF FIVE MILE ROAD (60 FEET WIDE, 1/2 WIDTH); THENCE S. 00°09'50" E. 485.31 FEET; THENCE S. 65°21'16" E. 107.24 FEET; THENCE S. 00°09'50" E. 222.64 FEET TO THE NORTHERLY RIGHT OF WAY OF THE CHESAPEAKE AND OHIO RAILROAD (99 FEET WIDE); THENCE ALONG SAID NORTHERLY RIGHT OF WAY LINE N. 65°21'16" W. 727.80 FEET TO THE WEST LINE OF SAID SECTION 20, ALSO BEING THE CENTERLINE OF RIDGE ROAD (60 FEET WIDE, 1/2 WIDTH); THENCE ALONG SAID LINE N. 00°05'01" E. 447.57 FEET TO THE POINT OF BEGINNING, CONTAINING 346,684 SQUARE FEET OR 7.96 ACRES OF LAND MORE OR LESS.

LEGAL DESCRIPTION (RESULTANT PARCEL 'B')

A PARCEL OF LAND LOCATED IN THE NORTH 1/2 OF SECTION 20, T. 1 S., R. 8 E., PLYMOUTH TOWNSHIP, WAYNE COUNTY, MICHIGAN, MORE PARTICULARLY DESCRIBED AS: COMMENCING AT THE NORTH 1/4 CORNER OF SAID SECTION 20; THENCE S. 89°45'02" E. 1119.41 FEET ALONG THE NORTH LINE OF SAID SECTION, ALSO BEING THE CENTERLINE OF FIVE MILE ROAD (60 FOOT EASEMENT, 1/2 WIDTH); THENCE S. 01°03'21" W. 425.00 FEET; THENCE S. 89°45'02" E. 200.00 FEET; THENCE S. 01°03'21" W. 2107.18 FEET TO THE NORTHERLY RIGHT OF WAY OF THE CHESAPEAKE AND OHIO RAILROAD (99 FEET WIDE); THENCE THE FOLLOWING FOUR (4) COURSES ALONG SAID NORTHERLY RIGHT OF WAY LINE 1) 116.58 FEET ALONG AN ARC OF A CURVE TO THE LEFT, RADIUS 2596.27 FEET, CENTRAL ANGLE 02°34'22" AND A CHORD THAT BEARS N. 56°44'27" W. 116.57 FEET, 2) N. 55°27'04" W. 1052.13 FEET, 3) 672.29 FEET ALONG THE ARC OF A CURVE TO LEFT, RADIUS 3889.51 FEET, CENTRAL ANGLE 09°54'12" AND A CHORD THAT BEARS N. 60°24'17" W. 671.45 FEET AND N. 65°21'16" W. 1886.41 FEET; THENCE N. 00°09'50" W. 222.64 FEET; THENCE N. 65°21'16" W. 107.24 FEET; THENCE N. 00°09'50" W. 485.31 FEET TO A POINT ON SAID NORTH LINE OF SECTION 20 AND CENTERLINE OF FIVE MILE ROAD; THENCE ALONG SAID LINE N. 89°50'10" E. 2089.23 FEET TO THE POINT OF BEGINNING, CONTAINING 5,124,253 SQUARE FEET OR 117.64 ACRES.

CERTIFICATION:

I HEREBY CERTIFY THAT THIS DRAWING IS A TRUE AND CORRECT REPRESENTATION OF EXISTING CONDITIONS. THERE ARE NO ENCROACHMENTS EITHER WAY ACROSS THE PROPERTY EXCEPT AS MAY BE SHOWN. THE RELATIVE ERROR OF CLOSURE OF THE LATITUDES AND DEPARTURES OF THE UNADJUSTED FIELD TRAVERSE IS NOT GREATER THAN 1 PART IN 5,000. THIS SURVEY WAS PREPARED UNDER MY SUPERVISION IN ACCORDANCE WITH ACT 132 OF THE PUBLIC ACTS OF 1970.



3-27-18 *Richard Hofsess*
 DATE RICHARD A. HOFSESS
 PROFESSIONAL SURVEYOR
 No. 47955

REVISIONS			PARCEL SPLIT		DATE	SCALE	
ITEM	DATE	BY			3-20-18	HOR: 1" =	
ADD SETBACKS	3-27-18	PTG	PLYMOUTH TOWNSHIP, WAYNE COUNTY, MICHIGAN		FIELD BOOK NO.		© COPYRIGHT 2018
			 Civil Engineers & Land Surveyors 55800 GRAND RIVER AVE, SUITE 100 NEW HUDSON, MICHIGAN 48165 P: (248) 437-5099 F: (248) 437-5222 www.zeimetwozniak.com		DESIGNED BY	JOB NO.	
					RH	17157	
					DRAWN BY	SHEET NO.	
			PTG	3/3			

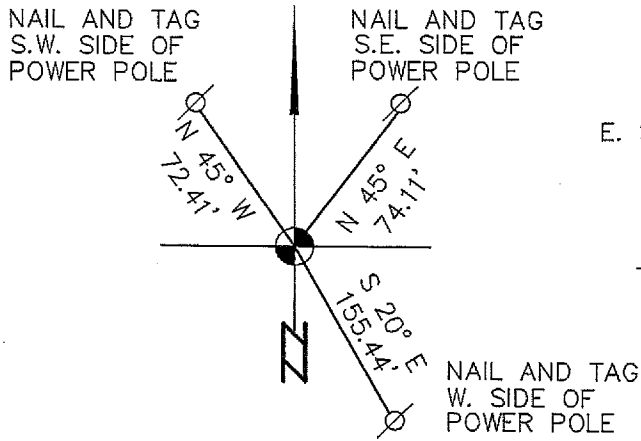

N.W. COR. SECTION 20
T. 1 S., R. 8 E.
PLYMOUTH TOWNSHIP,
WAYNE COUNTY, MI.
(MON IN MON BOX)
L.C.R.C. L. 27003, P. 586

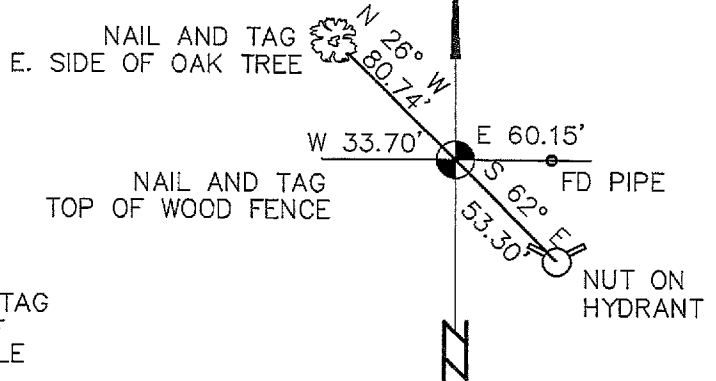

W. 1/4 COR. SECTION 20
T. 1 S., R. 8 E.
PLYMOUTH TOWNSHIP,
WAYNE COUNTY, MI.
(DISC IN MON BOX)
L.C.R.C. L. 41849, P. 161

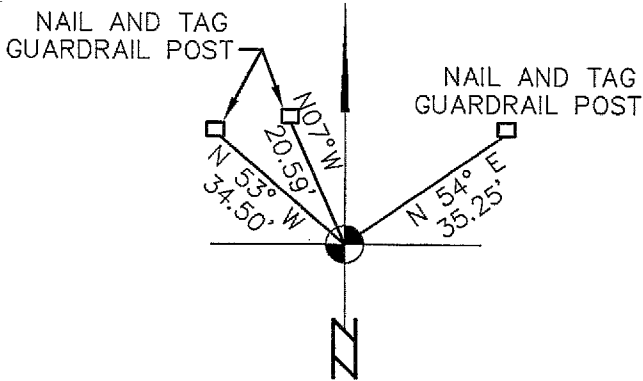

N. 1/4 COR. SECTION 20
T. 1 S., R. 8 E.
PLYMOUTH TOWNSHIP,
WAYNE COUNTY, MI.
(DISC ON IRON ROD)
L.C.R.C. L. 41849, P. 167

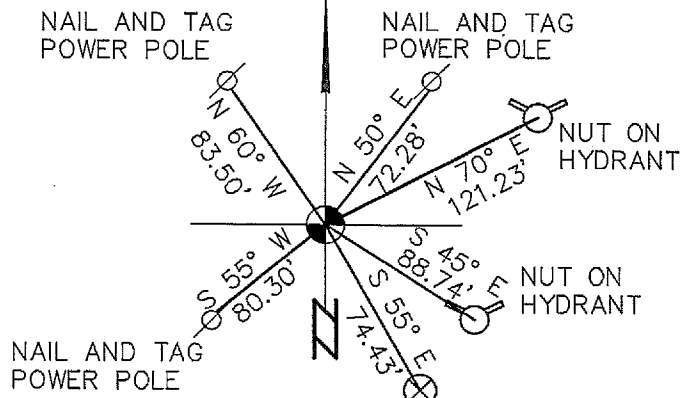

N.E. COR. SECTION 20
T. 1 S., R. 8 E.
PLYMOUTH TOWNSHIP,
WAYNE COUNTY, MI.
(MON IN MON BOX)
L.C.R.C. L. 27800, P. 29

REVISIONS			PARCEL SPLIT		DATE	SCALE
ITEM	DATE	BY	PLYMOUTH TOWNSHIP, WAYNE COUNTY, MICHIGAN		3-20-18	HOR: 1" =
ADD SETBACKS	3-27-18	PTG	<p>Civil Engineers & Land Surveyors 55800 GRAND RIVER AVE, SUITE 100 NEW HUDSON, MICHIGAN 48165 P: (248) 437-5099 F: (248) 437-5222 www.zeimetwozniak.com</p>			FIELD BOOK NO.
					DESIGNED BY	JOB NO.
					RH	17157
					DRAWN BY	SHEET NO.
					PTG	2/3

© COPYRIGHT 2018

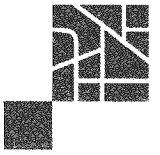

MCKENNA

May 9, 2018

Supervisor Kurt Heise
Charter Township of Plymouth
9955 N. Haggerty Road
Plymouth, MI 48170

RE: P.C. No: 2284-0418
 Project Name: 47500 Five Mile – Lot Split
 Applicant: David Hardin (Hillside Realty) and the State of Michigan
 Tax ID No.(s): R-78-006-99-0001-701
 Location / Address: 47500 Five Mile Road
 Zoning: IND, Industrial
 Review No.: Written Review #2

Dear Supervisor Heise,

The above land division application has been reviewed for conformance to the Township Zoning Ordinance No. 99 and the Michigan Land Division Act, P.A. 288 of 1967, as amended.

The applicant, Mr. David Hardin of Hillside Realty, proposes to split parcel R-78-006-99-0001-701 into two (2) new buildable parcels. These two Parcels: "Parcel A" and "Parcel B", are illustrated in the certified survey prepared by *Zeimet, Wozniak & Associates*. The existing parent parcel is located at the south east corner of the Five Mile and Ridge Road intersection, is zoned the IND, Industrial district, and consists of a vacant land.

The following comments are offered for your consideration:

1. Certified Survey

As noted above, a certified survey prepared by *Zeimet, Wozniak & Associates* was provided with the application which details the existing parent parcel, its associated legal description, and the resulting two (2) proposed Parcels, each with a new legal description. This condition is met.

2. Dimensional / Zoning Requirements

The resulting Parcels A and B comply with the dimensional standards of the IND district and are considered buildable, conforming lots.

As vacant parcels, these two sites could potentially be developed as an "Industrial and Research Park", as provided for in Section 20.2(ee) of the Township's Zoning Ordinance. Such an Industrial and Research Park requires different dimensional standards than the traditional IND, Industrial district, which have also been evaluated against Parcels A and B for conformity. Both Parcels A and B comply with the dimensional standards of the Industrial and Research Park, should that development option be preferred in the future.

Please note, per Section 28.2.3.c. of the Zoning Ordinance, Standards for Approval for Lot Splits, "Each resulting parcel shall have access to...sidewalks, road access and other improvements..." In order to

comply with the Zoning Ordinance, a new sidewalk must be installed and so detailed on the site plan with the Planning Commission, prior to the issuance of final site plan approval.

3. Utilities

Per the requirements of the Township's Ordinance, the applicant has submitted documentation that Plymouth Township is not responsible for the extension of any utilities to any lot created through this land split. This condition is met.

4. Previous Land Splits

The applicant has confirmed that the parent parcel has not been split within the past ten years and has provided documentation to this effect. A previous split was completed on March 7, 2006. This condition is met.

FINDINGS

Based on the findings above, the proposed land division for Parcel R-78-006-99-0001-701 is recommended for approval by the Township Supervisor, conditional upon:

A sidewalk constructed along all roadway frontages, with proper ADA crosswalk extensions, to be detailed on the site plan made with the Planning Commission, prior to the issuance of final site plan approval.



5/10/17

Signature Authorization: Supervisor Kurt Heise

Date

Respectfully submitted,

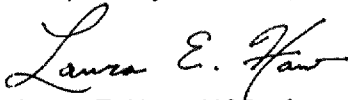

Laura E. Haw, AICP
Principal Planner, McKenna
Planning Director, Plymouth Township

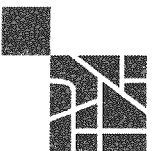

PARCEL 14

MITC PARCEL 14
LEGAL DESCRIPTION

20B2 TH NW 1/4 ALSO W 1/2 OF NE 1/4 SEC 20 T1S R8E EXC C AND O RR R.O.W. ALSO EXC ALL LAND N OF C.O.R.R.
R.O.W. 102.82 AC K102.82

APPENDIX E

PROJECT SITE PLANS AND CONCEPTUAL DRAWINGS - PARCEL 9 (NORTHVILLE LUMBER CO.) PARCEL 13, PARCEL 11/12

PARCEL 9 (NORTHVILLE LUMBER CO.)

BENCHMARKS:
SITE BM #1
 BENCH TIE ON SOUTH SIDE OF UTILITY POLE, 425.4' EAST OF CENTERLINE OF NAPIER ROAD
 ELEVATION: 876.69 N.A.V.D.88 DATUM
SITE BM #2
 GEAR PIN IN SOUTHWEST SIDE OF POWER POLE, NORTHEAST CORNER OF NAPIER ROAD AND 5 MILE ROAD
 ELEVATION: 874.12 N.A.V.D.88 DATUM
SITE BM #3
 BENCH TIE ON NORTHEAST FACE OF UTILITY POLE, 800' NORTH OF CENTERLINE 5 MILE ROAD WEST SIDE OF NAPIER ROAD
 ELEVATION: 894.08 N.A.V.D.88 DATUM
SITE BM #4
 NAIL IN NORTH SIDE OF TREE (#3735), NORTHWEST CORNER OF PROPERTY
 ELEVATION: 899.23 N.A.V.D.88 DATUM

- LEGEND**
- EX. SANITARY SEWER
 - EX. STORM SEWER
 - EX. WATER MAIN
 - EX. OVERHEAD UTILITY LINES
 - EX. MANHOLE
 - EX. CATCH BASIN
 - EX. HYDRANT
 - EX. GATE VALVE
 - EX. UTILITY POLE
 - EX. GUY WIRE
 - EX. IRON BAR
 - EX. SET IRON BAR
 - EX. SIGN
 - EX. UNKNOWN METER
 - EX. DECIDUOUS TREE

- HATCH LEGEND**
- ASPHALT
 - CONCRETE
 - PROPOSED BUILDING
 - EXISTING BUILDING
- ALL PROPOSED PAVEMENT CROSS-SECTIONS ARE PER NORTHVILLE TOWNSHIP SPECIFICATIONS, TYP

DETENTION BASIN SIZING CALCULATIONS:

BASIN	ELEVATION	AREA	AVG AREA	HEIGHT	VOLUME	CUMULATIVE VOLUME
831	73,358		77,200	1.0	77,200	77,200
832	81,041	84,996	84,996	1.0	84,996	162,196
833	88,951	88,019	88,019	1.0	88,019	250,214
834	87,000	95,267	95,267	1.0	95,267	345,481
835	105,448	106,742	106,742	1.0	106,742	452,223
836	114,026	118,443	118,443	1.0	118,443	574,666
837	122,850	127,371	127,371	1.0	127,371	702,037
838	131,861					
839						

	Req Vol	Elev
Permanent Water Elevation	410,305	826.00
CFRDC	697,823	831.97
100-yr Elevation (provided)	702,037	838.00
Freeboard Elevation		838.00

Detention Basin Design for 100-Year Design Storm

Time of Concentration Calculations

Sheet Flow
 $V = 4.83 \sqrt{S}$
 $V =$ velocity
 $S =$ slope of sheet flow
 $V = 0.48$ ft/s
 $A =$ area (acres)

Flow time = 3.5 min
 $L = 100$ ft
 $L =$ flow length

Shallow Flow
 $V = 4.83 \sqrt{S}$
 $K = 1.2$
 $S = 1.00$ %
 $V = 1.30$ ft/s
 $S =$ slope (%)

Flow time = 0.5 min
 $L = 60$ ft
 $L =$ flow length

Sewer Flow
 $V = 3.0$ ft/s (average velocity from sewer flow)
 $V = 3.0$ ft/s
 $L = 320$ ft
 $L =$ flow length

Flow time = 3.5 min
 $L =$ flow length

Time of Concentration = Sheet Flow + Shallow Flow + Sewer Flow
 $T = 31.3$ min

100-Year Detention Volume

$Q_{100} = 1.1055 \cdot (0.2071)^{0.1667} A$
 $Q_{100} =$ 100-yr allowable release rate (cf/acre)
 $A =$ area (acres)

$Q_{100} = 0.21$ cfs/acre
 $Q_{100} = 15.86$ cfs

$Q_{100} = C \cdot I \cdot A$
 $Q_{100} =$ 100-yr peak allowable discharge (cfs)
 $A =$ area (acres)

$C = 0.80$
 $I_{100} = 100$ yr peak rainfall intensity (in/hr)
 $A =$ area (acres)

$C = 0.80$
 $I_{100} = 4.2$ in/hr
 $Q_{100} = 251.86$ cfs

$V = 18,900 \cdot C \cdot I \cdot A$
 $V =$ 100-yr runoff volume (cf)
 $C =$ runoff coefficient
 $I =$ 100-yr peak rainfall intensity (in/hr)
 $A =$ area (acres)

$V = 1,124,531$ cf

$V_1 / V_2 = 0.206 \cdot (Q_1 / Q_2)$
 $V_1 / V_2 =$ storage ratio
 $Q_1 =$ 100-yr peak allowable discharge (cfs)
 $C =$ runoff coefficient

$Q_1 = 15.86$ cfs
 $Q_2 = 251.86$ cfs
 $V_1 / V_2 = 0.02$

100-yr Required Storage Volume

$V_1 = V_2 \cdot$ storage ratio
 $V_1 =$ 100-yr required storage volume (cf)
 $V_2 =$ 100-yr runoff volume (cf)
 $V_1 / V_2 =$ storage ratio

$V_1 = 697,823$ cf

Flood Control Volume

$V_{flood} = 697,823$ cf

First Flush Volume & Release Rate

$V_1 = 545 \cdot A \cdot C$
 $V_1 =$ first flush volume (cf)
 $C =$ runoff coefficient
 $A =$ area (acres)

$Q_{100} = V_1 / 16,400$
 $Q_{100} =$ 24-hr avg. allowable outflow rate (cf)

$Q_{100} = 0.38$ cfs

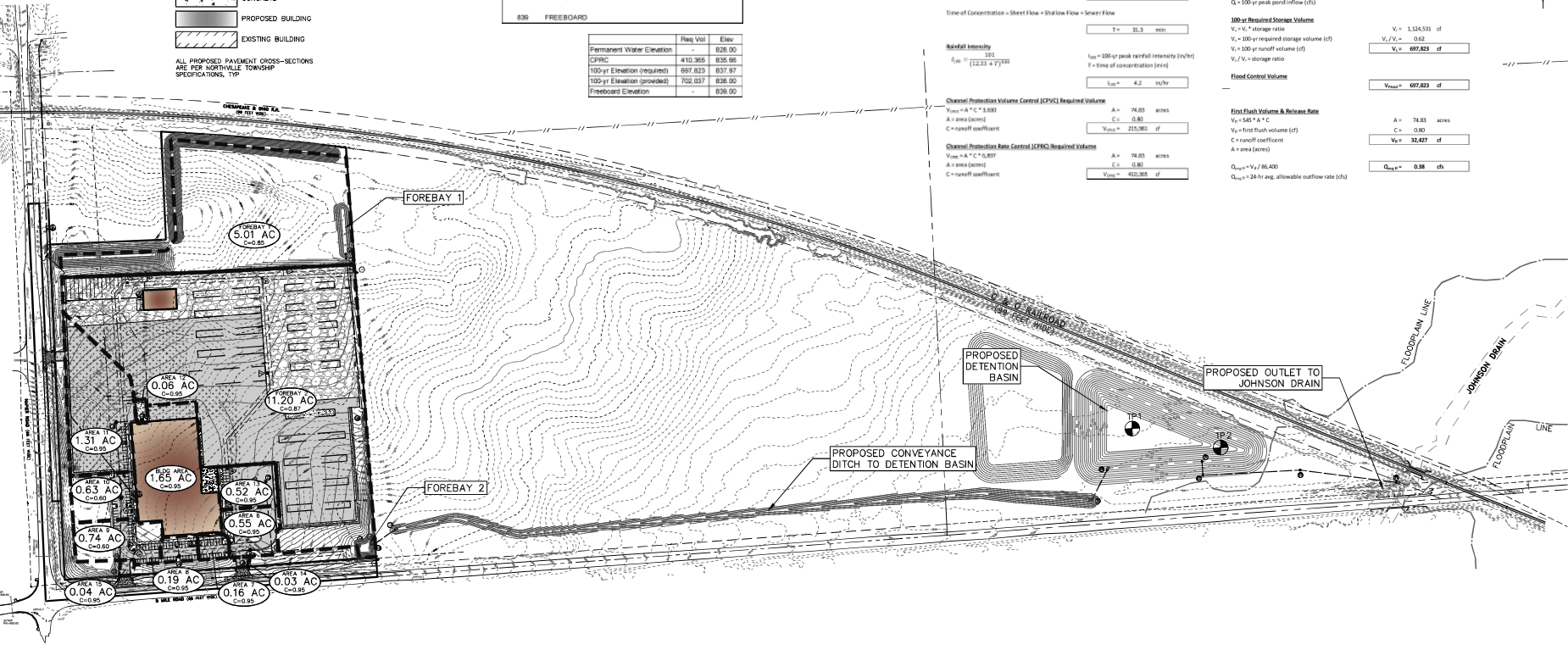

Sub-Tributary	Tributary Area (Acres)	Impervious (C=0.95)	Permeous (C=0.25)	Perm Water (C=1)	Composites C
1	0	0	0	0	0
2	0	0	0	0	0
3	0	0	0	0	0
4	0	0	0	0	0
5	0	0	0	0	0
6	0.55	0.55	0	0	0.95
7	0.16	0.16	0	0	0.95
8	0.16	0.16	0	0	0.95
9	0.74	0.37	0.37	0	0.60
10	0.63	0.32	0.32	0	0.60
11	1.31	1.31	0	0	0.95
12	0.06	0.06	0	0	0.95
13	0.52	0.52	0	0	0.95
14	0.03	0.03	0	0	0.95
15	0.04	0.04	0	0	0.95
16	0	0	0	0	0
17	0	0	0	0	0
18	0	0	0	0	0
BLDG	1.56	1.56	0.00	0.00	0.95

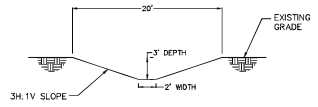

DETENTION BASIN DATA:

FREEBOARD ELEVATION = 838.0
 100 YR ELEVATION = 838.0
 PERMANENT WATER ELEVATION = 831.0
 BOTTOM ELEVATION = 825.0
 VOLUME REQUIRED = 697,823 CF
 VOLUME PROVIDED = 702,037 CF

GREENTECH ENGINEERING, INC.
 CIVIL ENGINEERS & LAND SURVEYORS
 81117 M. Pontiac Trail, Wixom, MI 48393
 Phone: (248) 868-0700 Fax: (248) 668-0701

811
 Know what's below
 Call before you dig.

STORMWATER MANAGEMENT PLAN

NORTHVILLE LUMBER - PARCEL 77-071-99-0002-701
 NORTHVILLE LUMBER - PARCEL 77-071-99-0002-701
 SECTION 18
 TOWNSHIP 1 S.
 RANGE 8 E.
 NORTHVILLE TOWNSHIP
 MICHIGAN

CLIENT: NORTHVILLE LUMBER

REVISED

DATE: 3-15-2023
 DRAWN BY: RMS
 CHECKED BY: LW

SCALE: HORIZ: 1"=50 FT
 VERT: 1"= 5 FT

18

20-372

THE STORMWATER DETENTION FOR THE PROPOSED SITE IS ACCOMMODATED WITHIN THE REGIONAL ON-SITE DETENTION BASIN AS SHOWN.



Proposed Exterior Rendering for:





Proposed Exterior Rendering for:





Proposed Exterior Rendering for:



PARCEL 13







PARCEL 11/12

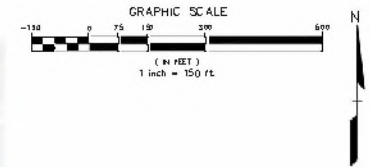

Ridge 5 Corporate Park

Plymouth Township, MI

June, 2018

